



WORKSHOP, SERVICE AND SAFETY

BEARINGS



Large stock of roller bearings, ball bearings, angular contact ball bearings, tapered bearings, spherical roller bearings and thrust ball bearings.

AETNA, BCA, BOWER,
 DKF DURKOPP, ELGES,
 FAFNIR, FAG,
 FED.MOGUL, FYH, GNUT-
 TI, GPZ, HIC, HOOVER,
 IKO, INA, KAYDON, KOYO,
 MCGILL, MRC, MRK,
 NEW DEPARTURE, NACHI,
 NADELLA, NSK NTN,
 RBC, RHP, RIV, ROLLWAY,
 SKF, SNR, STEYR, TIM-
 KEN, TORRINGTON, URB,
 ZKL



TIE-ROD END

TIE-ROD END - INNER THREAD



Inner	REF
M5 with Ø 5 hole	106TA7849
M8 with Ø 8 hole	106TA7850
M14 with Ø 15 hole	106TA7851
M20 x 1,5 with Ø 20 hole	106TA7852
M30 with Ø 30 hole	106TA7853
M24 x 2 with Ø 25 hole	106TA7854

TIE-ROD END - OUTER THREAD



Outer	REF
M10 with Ø 10 hole	106TA7855
M20 x 1,5 with Ø 20 hole	106TA7856
M24 x 2 with Ø 25 hole	106TA7857
M30 x 2 with Ø 30 hole	106TA7860
M24 x 1,5 with Ø 25 hole	106TA7858
M18 x 1,5 with Ø 18 hole	106TA7859

SPECIAL OFFER

BEARINGS

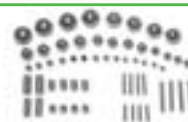

BEARING BALL

dia. (mm)	REF
10	107TA5922
10,319	107TA5923
11	107TA5924
11,906	107TA5925
11.112	107TA5926
12	107TA5927
12,7	107TA5928
13	107TA5929
13,494	107TA5930
13,5	107TA5931
14	107TA5932
14,288	107TA5933
15	107TA5934
15,875	107TA5935
16	107TA5936
17	107TA5937
17,462	107TA5938
18	107TA5939
18,256	107TA5940
19	107TA5941
19,05	107TA5942
2	107TA5943
2,381	107TA5944
20	107TA5945
20,638	107TA5946
21	107TA5947
22	107TA5948
22,225	107TA5949
22,5	107TA5950
23	107TA5951
23,812	107TA5952
25	107TA5953
25,4	107TA5954
3	107TA5955
3,175	107TA5956
3,5	107TA5957
3,969	107TA5958
3/16	107TA5959
3/8	107TA5960
4	107TA5961
4,762	107TA5962
45	107TA5963
5	107TA5964
5,5	107TA5965
5,92	107TA5966
6	107TA5967
6,35	107TA5968
6,5	107TA5969
7	107TA5970
7,144	107TA5971
7,4	107TA5972
7,5	107TA5973

7,938	107TA5974
7/16	107TA5975
8	107TA5976
8,5	107TA5977
8,731	107TA5978
9	107TA5979
9,52	107TA5980

BEARING ROLLER

dia. x length (mm)	REF
11 x 15	107TA5981
13 x 20	107TA5982
15 x 22	107TA5983
17 x 24CDSP	107TA5984
18 x 26CD	107TA5985
10 x 20	107TA5986
10 x 34,72	107TA5987
12,7 x 31,75	107TA5988
20 x 20	107TA5989
22 x 22CD	107TA5990
5 x 10	107TA5991
6,35 x 19,5	107TA5992
6,5 x 6,5	107TA5993
6 x 12	107TA5994
6 x 12,5	107TA5995
6 x 18	107TA5996
6 x 24	107TA5997
7,15 x 17,5	107TA5998
7 x 10	107TA5999
7 x 12	107TA6000
7 x 16	107TA6001
8 x 12	107TA6002
8 x 8	107TA6003
9,5 x 23,5	107TA6004
9 x 14	107TA6005

BEARING NEEDLE

dia. x length (mm)	REF
1,8 x 9,15	107TA6006
2,4 x 20,3	107TA6007
2,5 x 7,8BF	107TA6008
2,5 x 17,8B	107TA6009
3,2 x 43,8-BF	107TA6010
3,5 x 15,7	107TA6011
3,5 x 34,8B	107TA6012
3,96 x 22,25B	107TA6013
4 x 39,8BF	107TA6014
1,58 x 12,7B	107TA6015
1,58 x 17,5B	107TA6016
1,97 x 18,8	107TA6017

1/4 x 1	107TA6018
1/8 x 1/2	107TA6019
1/8 x 25B	107TA6020
2,37 x 22,08	107TA6021
2,4 x 24,6B	107TA6022
2,5 x 15,8B	107TA6023
2 x 158BF	107TA6024
2 x 178BF	107TA6025
2 x 6,8BF	107TA6026
2 x 9,8B	107TA6027
3,175 x 14,22B	107TA6028
3,175 x 22,35-B	107TA6029
3,175 x 28,23BF	107TA6030
3,17 x 15,87B	107TA6031
3,17 x 18,8	107TA6032
3,17 x 20,637B	107TA6033
3,17 x 34,8B	107TA6034
3,17 x 9,52B	107TA6035
3,2 x 44	107TA6036
3,5 x 29,8B	107TA6037
3,5 x 29,8BF	107TA6038
3,5 x 37	107TA6039
3,5 x 44BF	107TA6040
3 x 12,7	107TA6041
3 x 15,8BF	107TA6042
3 x 17,8B	107TA6043
3 x 19,8B	107TA6044
3 x 23,7B	107TA6045
3 x 23,8B	107TA6046
3 x 27,8b	107TA6047
3 x 31,75B	107TA6048
3 x 9,8BF	107TA6049
4,76 x 20,43B	107TA6050
4,76 x 25,4B	107TA6051
4,76 x 28,57B	107TA6052
4,76 x 30,16B	107TA6053
4,76 x 34,7BF	107TA6054
4 x 16,6B	107TA6055
4 x 27,8B	107TA6056
4 x 29,7B	107TA6057
4 x 31,7B	107TA6058
4 x 39,7B	107TA6059
4 x 40	107TA6060
4 x 41,5BF	107TA6061
5,55 x 34,92BF	107TA6062
5 x 23B	107TA6063
6,35 x 31,75B	107TA6064
6 x 22	107TA6065
7,93 x 23,81BF	107TA6066
7,93 x 25,4B	107TA6067
8,18 x 23,8BF	107TA6068
8,2 x 23,8B	107TA6069
8 x 16	107TA6070
8 x 20B	107TA6071
8 x 22	107TA6072
9,525 x 23,81BF	107TA6073

TECHNICAL DETAIL: GAS STRUTS

EXAMPLE



Company:

Customer code:

Name:

Fax number:

Truck make:

Truck type: Serial nr.:

- 1 TY type, see pictures
- 2 TA1 type of thread 1
- 3 PM pitch (metric)
- 4 PI pitch (inch)
- 5 RH/LH right or left hand thread
- 6 TA2 type of thread 2
- 7 PM pitch (metric)
- 8 PI pitch (inch)
- 9 RH/LH right or left hand thread
- 10 L measurement L, see pictures (mm)
- 11 H measurement H, see pictures (mm)

Type A: Inner thread



Type B: Outer thread





GAS STRUTS

USED FOR HYSTER

REF	105TA1418
TY	A
TA1	3/16 UNF
Pm	0
Pi	32
RH/LH	RH
TA2	1/4 UNF
Pm	0
Pi	28
RH/LH	RH
L	22
H	25



USED FOR TOYOTA

REF	105TA1468
TY	A
TA1	M6
Pm	1
Pi	0
RH/LH	LH
TA2	M6
Pm	1
Pi	0
RH/LH	RH
L	25
H	22



USED FOR TCM

REF	105TA1492
TY	A
TA1	M8
Pm	1,25
Pi	0
RH/LH	RH
TA2	M8
Pm	1,25
Pi	0
RH/LH	RH
L	29
H	31



USED FOR LINDE

REF	105TA1461
TY	A
TA1	M5
Pm	0,8
Pi	0
RH/LH	LH
TA2	M5
Pm	0,8
Pi	0
RH/LH	RH
L	22
H	18,5



USED FOR LINDE

REF	105TA1477
TY	A
TA1	M6
Pm	1
Pi	0
RH/LH	RH
TA2	M6
Pm	1
Pi	0
RH/LH	RH
L	25
H	23



USED FOR LINDE

REF	105TA1463
TY	A
TA1	M5
Pm	0,8
Pi	0
RH/LH	RH
TA2	M5
Pm	0,8
Pi	0
RH/LH	RH
L	22
H	19



USED FOR LINDE

REF	105TA1486
TY	A
TA1	M8
Pm	1,25
Pi	0
RH/LH	RH
TA2	M8
Pm	1,25
Pi	0
RH/LH	RH
L	30
H	28



USED FOR LINDE

REF	105TA1480
TY	A
TA1	M8
Pm	1,25
Pi	0
RH/LH	LH
TA2	M8
Pm	1,25
Pi	0
RH/LH	RH
L	29
H	27



USED FOR LINDE

REF	105TA1469
TY	A
TA1	M6
Pm	1
Pi	0
RH/LH	RH
TA2	M6
Pm	1
Pi	0
RH/LH	RH
L	25
H	22



USED FOR CLARK

REF	105TA1436
TY	A
TA1	3/8 UNF
Pm	0
Pi	24
RH/LH	RH
TA2	3/8 UNF
Pm	0
Pi	24
RH/LH	RH
L	35
H	38



This is only a small selection of what we can offer. Call our sales department for more details.

SEALS



SEAL TYPES

TYPE V • V SEAL

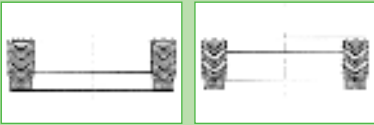

TYPE X • X SEAL

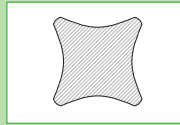

TYPE C • COMPOSITE SEAL



TYPE C1

TYPE C2

TYPE C3

TYPE C4

TYPE C5

TYPE C6

TYPE P • PISTON SEAL

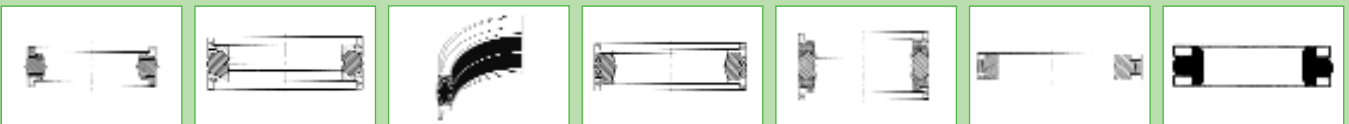

TYPE P1

TYPE P2

TYPE P3

TYPE P4

TYPE P5

TYPE P6

TYPE P7

TYPE G • GUIDE RING



TYPE G1

TYPE G2

TYPE G3



*We can offer a complete range of seals for any make
Supply us with measurements and type of seal*

HYDRAULIC & PNEUMATIC SEALS

HYDRAULIC & PNEUMATIC SEALS

<p>TYPE: R01</p>   <p>Type: R01</p>	<p>TYPE: R02</p>   <p>Type: R02</p>	<p>TYPE: R03</p>   <p>Type: R03</p>
<p>TYPE: R04</p>   <p>Type: R04</p>	<p>TYPE: R05</p>   <p>Type: R05</p>	<p>TYPE: R06</p>   <p>Type: R06</p>
<p>TYPE: R07</p>   <p>Type: R07</p>	<p>TYPE: R08</p>   <p>Type: R08</p>	<p>TYPE: R09</p>   <p>Type: R09</p>
<p>TYPE: R10</p>   <p>Type: R10</p>	<p>TYPE: R11</p>   <p>Type: R11</p>	<p>TYPE: R12</p>   <p>Type: R12</p>
<p>TYPE: R14</p>   <p>Type: R14</p>	<p>TYPE: R15</p>   <p>Type: R15</p>	<p>TYPE: R23</p>   <p>Type: R23</p>

 ***This is only a small selection of what we can offer. Call our sales department for more details.***

 ***Colours of parts received can differ from colours shown in catalogue***

We are able to send you an offer when choosing correct type of seal with inner diameter, outer diameter and width of the seal.

HYDRAULIC & PNEUMATIC SEALS

<p>TYPE: U01</p>   <p>Type: U01</p>	<p>TYPE: U02</p>   <p>Type: U02</p>	<p>TYPE: U03</p>   <p>Type: U03</p>
<p>TYPE: U05</p>   <p>Type: U05</p>	<p>TYPE: U06</p>   <p>Type: U06</p>	<p>TYPE: U07</p>   <p>Type: U07</p>
<p>TYPE: U08</p>   <p>Type: U08</p>	<p>TYPE: U09</p>   <p>Type: U09</p>	<p>TYPE: U10</p>   <p>Type: U10</p>
<p>TYPE: U12</p>   <p>Type: U12</p>	<p>TYPE: U13</p>   <p>Type: U13</p>	<p>TYPE: U14</p>   <p>Type: U14</p>
<p>TYPE: U17</p>   <p>Type: U17</p>		

 ***This is only a small selection of what we can offer. Call our sales department for more details.***

 ***Colours of parts received can differ from colours shown in catalogue***

We are able to send you an offer when choosing correct type of seal with inner diameter, outer diameter and width of the seal.

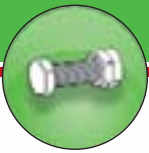

O-RINGS

Different qualities available from stock NBR 70, NBR 80, NBR 90, Silicone O-rings, Viton and EPDM O-rings. We currently stock more than 3500 different dimensions.

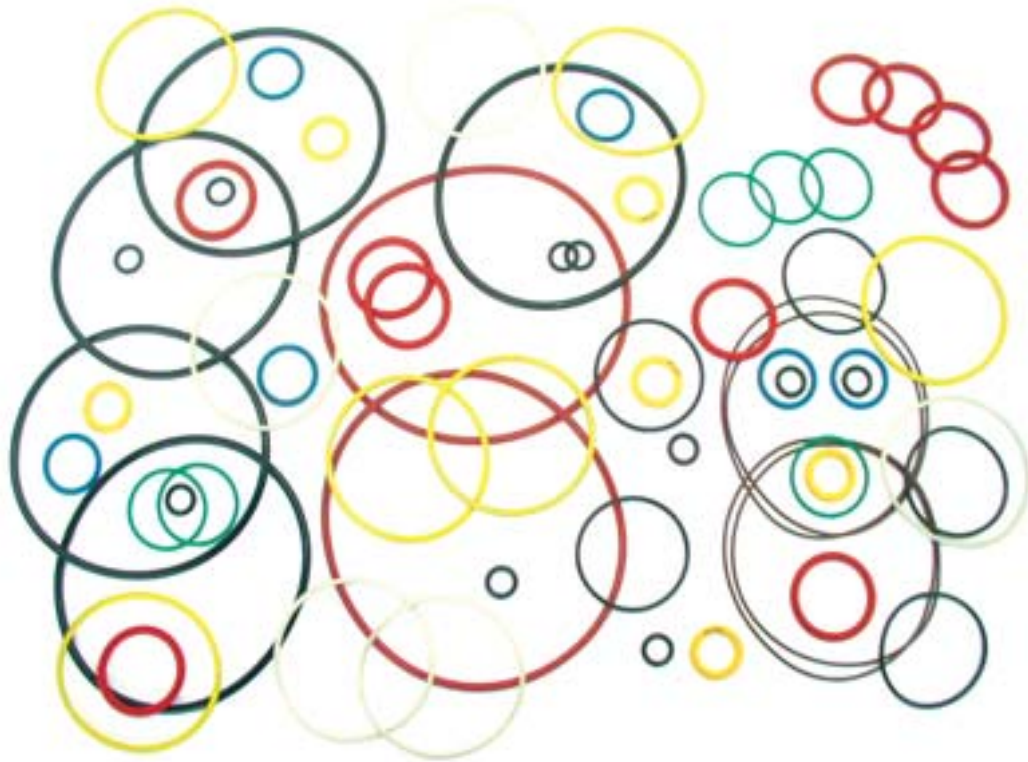

We are able to send you an offer when you give us the inner diameter and width of O-rings.

O-RINGS

TO MEASURE O-RINGS



REF 115TA6899 Ø 2 - 20 mm



REF 115TA6900 Ø 20- 100 mm



REF 115TA6901 Ø 100 - 160 mm



SEALS ASSEMBLY KIT



REF 122TA7765

For easy fitting and detaching of o-rings without any damage

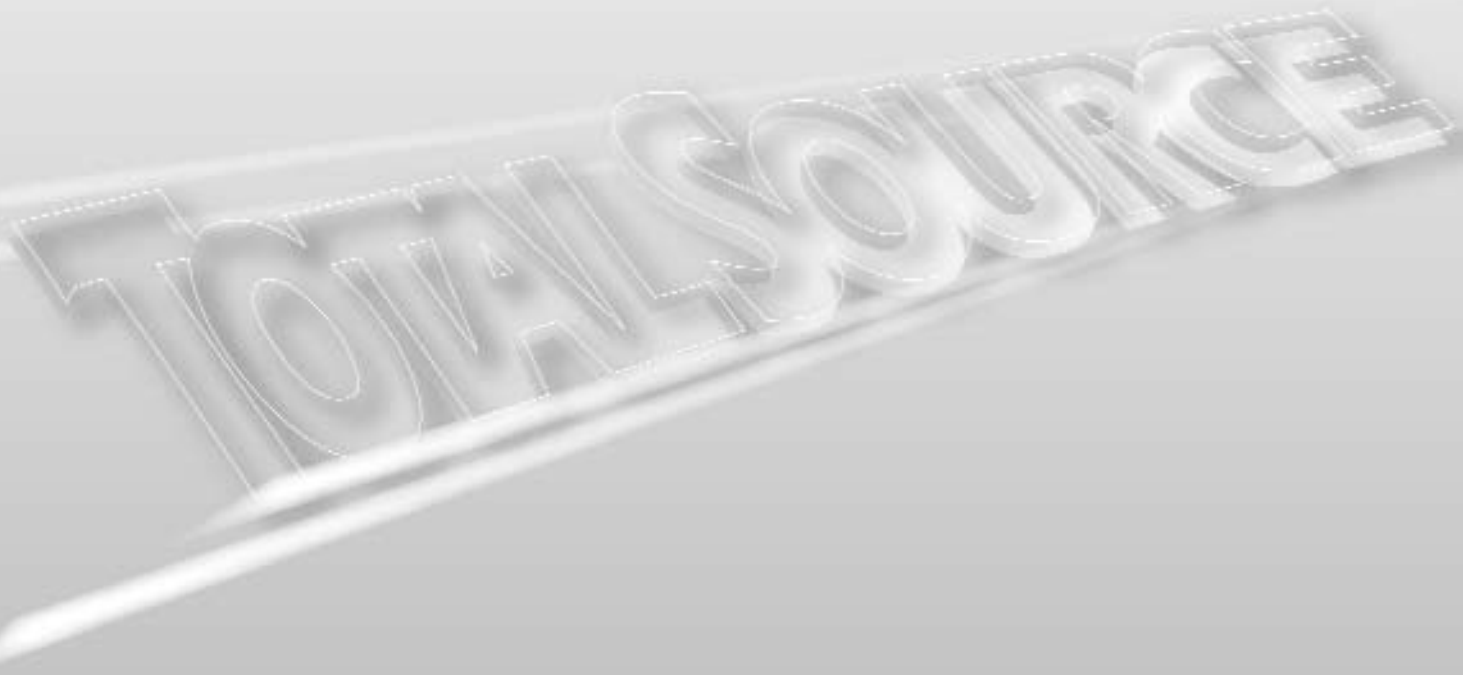



Also boxes of x-rings and back-up rings available. Please contact our sales department for dimensions and availability.



O-RING SETS

REF 107TA5439

Dimensions	Qty.	Dimensions	Qty.	Dimensions	Qty.
18,0 X 2	15	25,0 x 4	15	48,0 x 4	10
20,0 X 2	15	30,0 x 4	15	50,0 x 4	10
22,0 X 3	15	32,0 x 4	15	25,0 x 5	10
25,0 X 3	15	34,0 x 4	15	30,0 x 5	10
28,2 X 3	15	36,0 x 4	15	35,0 x 5	10
30,2 X 3	15	38,0 x 4	10	40,0 x 5	10
32,2 X 3	10	40,0 x 4	10	45,0 x 5	5
36,2 X 3	10	44,0 x 4	10	50,0 x 5	5

REF 107TA5438

Dimensions	Qty.	Dimensions	Qty.	Dimensions	Qty.
2,8x1,9	22	15,8 x 2,5	13	32 x 3,5	10
3,8x1,9	22	17,8 x 2,5	13	33 x 3,5	10
4,8x1,9	20	19 x 2,5	13	35 x 3,5	10
5,8x1,9	19	19 x 3,5	10	36 x 3,5	11
6,8x1,9	19	21 x 3,5	10	38 x 3,5	10
7,8x1,9	19	22 x 3,5	10	38 x 5,3	7
8,8x1,9	19	24 x 3,5	10	41 x 5,3	7
9,8x2,5	13	25 x 3,5	10	44 x 5,3	7
10,8x2,5	13	26 x 3,5	10		
11,8x2,5	13	28 x 3,5	10		
13,8x2,5	13	30 x 3,5	10		

REF 107TA5437

Dimensions	Qty.	Dimensions	Qty.	Dimensions	Qty.
3,0 x 2	16	14,0 x 2,5	13	28,0 x 3	12
4,0 x 2	16	16,0 x 2,5	13	30,0 x 3	12
5,0 x 2	16	17,0 x 2,5	13	32,0 x 3	12
6,0 x 2	16	19,0 x 2,5	13	33,0 x 3	12
7,0 x 2	16	19,0 x 3	11	35,0 x 3	12
8,0 x 2	16	20,0 x 3	12	36,0 x 3	12
10,0 x 2	16	22,0 x 3	12	38,0 x 3	12
10,0 x 2,5	13	24,0 x 3	12	38,0 x 4	9
11,0 x 2,5	13	25,0 x 2,5	11	41,0 x 4	9
12,0 x 2,5	13	27,0 x 3	11	44,0 x 4	9

REF 107TA5440

Dimensions	Qty.	Dimensions	Qty.	Dimensions	Qty.
3,0 X 2	20	11,3 x 2,4	15	15,0 x 3	10
4,0 X 2	20	12,3 x 2,4	15	18,0 x 3	10
5,0 X 2	20	13,3 x 2,4	15	19,2 x 3	10
6,0 X 2	20	14,3 x 2,4	15	24,2 x 3	10
7,0 X 2	20	15,3 x 2,4	15	39,2 x 3	10
8,0 X 2	20	16,3 x 2,4	15	44,2 x 3	10
9,0 X 2	20	17,3 x 2,4	15	49,2 x 3	10
10,0 X 2	20	18,3 x 2,4	15	39,5 x 3,5	10
9,3 X 2,4	15	19,3 x 2,4	15	44,5 x 3,5	10
10,3 X 2,4	15	20,3 x 2,4	15	49,2 x 5,7	5

REF 107TA5434

Dimensions	Qty.	Dimensions	Qty.	Dimensions	Qty.
2,90 x 1,78	20	9,25 x 1,78	20	34,52 x 3,53	10
3,68 x 1,78	20	15,54 x 2,62	13	32,92 x 3,53	10
4,48 x 1,78	20	17,13 x 2,62	13	31,34 x 3,53	10
5,28 x 1,78	20	18,72 x 2,62	13	29,75 x 3,53	10
6,07 x 1,78	20	18,64 x 3,53	10	20,22 x 3,53	10
7,66 x 1,78	20	37,69 x 3,53	10	21,82 x 3,53	10
13,95 x 2,62	13	37,47 x 5,33	7	23,40 x 3,53	10
12,37 x 2,62	13	40,65 x 5,33	7	24,99 x 3,53	10
10,78 x 2,62	13	43,82 x 5,33	7	26,58 x 3,53	10
9,19 x 2,62	13	36,10 x 3,53	10	28,17 x 3,53	10

REF 107TA5435

Dimensions	Qty.	Dimensions	Qty.	Dimensions	Qty.
3,0 x 1,5	20	6,3 x 2,4	15	10,0 x 3	10
5,0 x 1,5	20	8,3 x 2,4	15	12,0 x 3	10
7,0 x 1,5	20	11,3 x 2,4	15	14,0 x 3	10
9,0 x 1,5	20	13,3 x 2,4	15	16,0 x 3	10
11,0 x 1,5	20	17,3 x 2,4	15	18,0 x 3	10
6,0 x 2	20	5,0 x 2,5	15	20,2 x 3	5
8,0 x 2	20	7,0 x 2,5	15	22,2 x 3	5
10,0 x 2	20	10,0 x 2,5	15	24,2 x 3	5
12,0 x 2	20	12,0 x 2,5	15	26,2 x 3	5
14,0 x 2	20	15,0 x 2,5	15	30,2 x 3	5

REF 107TA5436

Dimensions	Qty.	Dimensions	Qty.	Dimensions	Qty.
2,90 x 1,78	20	15,60 x 1,78	10	20,29 x 2,62	5
3,68 x 1,78	20	17,16 x 1,78	5	21,89 x 2,62	5
4,48 x 1,78	20	18,77 x 1,78	5	23,47 x 2,62	5
5,28 x 1,78	20	9,19 x 2,62	15	18,64 x 3,53	5
6,07 x 1,78	20	10,78 x 2,62	15	20,22 x 3,53	5
7,66 x 1,78	20	12,37 x 2,62	15	21,82 x 3,53	5
9,25 x 1,78	20	13,95 x 2,62	15	23,40 x 3,53	5
10,82 x 1,78	15	15,54 x 2,62	10	24,99 x 3,53	5
12,42 x 1,78	15	17,13 x 2,62	10	26,58 x 3,53	5
14,00 x 1,78	10	18,72 x 2,62	10	28,17 x 3,53	5

Also available in other variations of hardness

To re-order O-rings, please use reference 401 with adding inner dimension plus thickness of O-ring.

OIL SEALS



OIL SEALS



Type: S01	Type: S02	Type: S03	Type: S04	Type: S05	Type: S06	Type: S07	Type: S08
Type: S10	Type: S11	Type: S12	Type: S13	Type: S15	Type: S16	Type: S17	Type: S18
Type: S19	Type: S21	Type: S24	Type: S25	Type: S29	Type: S30	Type: S31	Type: S33

We have a complete range of seals available from stock. Rod seals, piston seals, wiper seals, rotary seals, guide elements, static seals, in all dimensions. (inch and metric)



We are able to send you an offer when choosing correct type of seal with inner diameter, outer diameter and width of the seal.



COMPLETE HYDRAULIC / PNEUMATIC SEALKITS

USED FOR MITSUBISHI



USED FOR STILL



USED FOR TCM



USED FOR TOYOTA

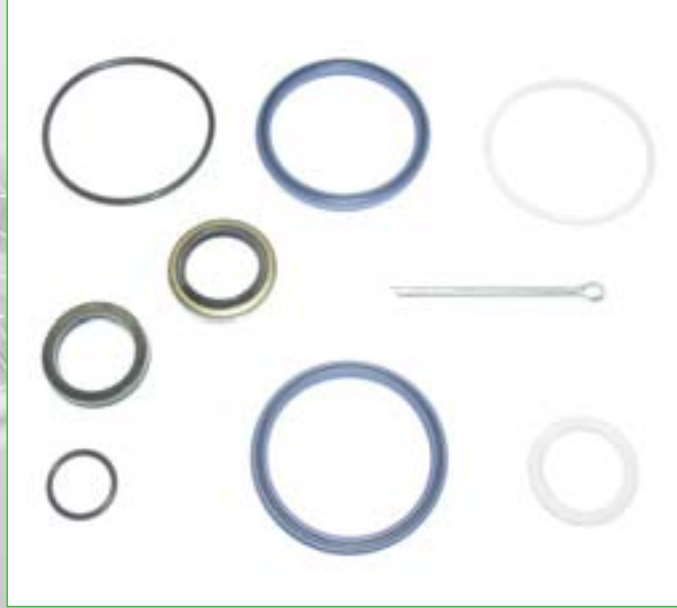

SEALKITS



We can offer a complete range of sealkits for any make. Supply us with measurements and type of each seal.

Full truck details are needed.

COMPLETE HYDRAULIC / PNEUMATIC SEALKITS

USED FOR BT



USED FOR CLARK

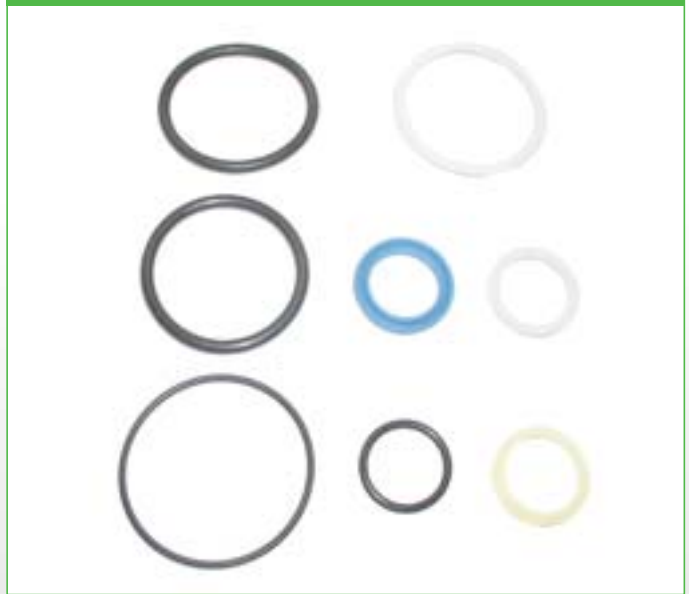

USED FOR DAEWOO

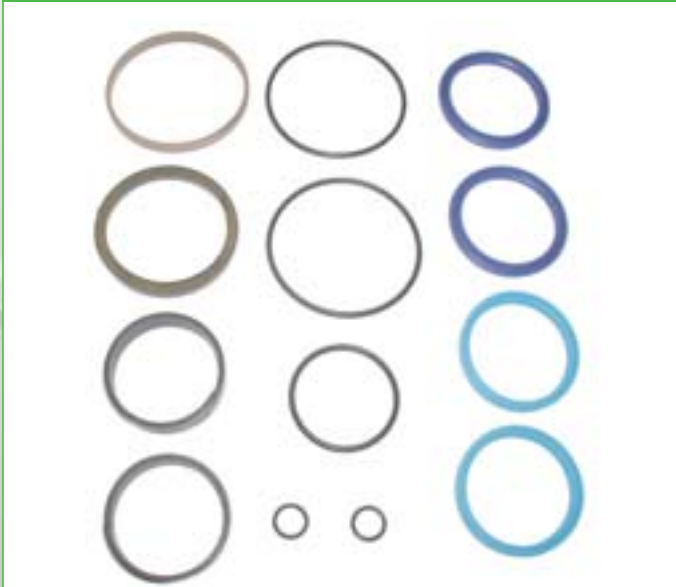

USED FOR HYSTER



USED FOR LINDE



USED FOR MIC

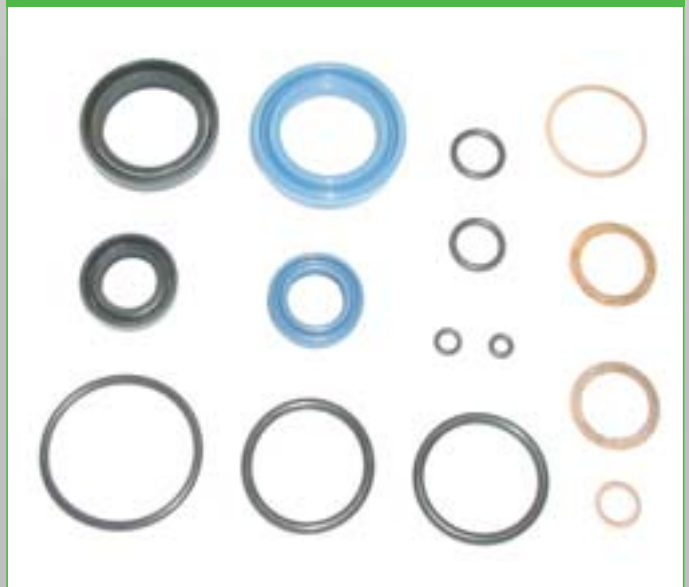

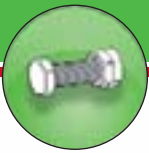

SPEEDI-SLEEVE®

SPEEDI-SLEEVE®

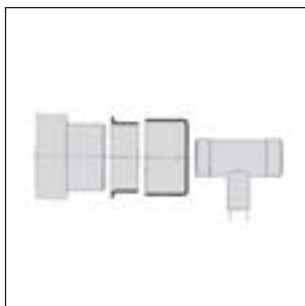
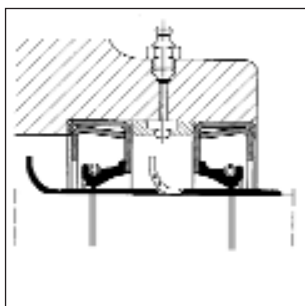
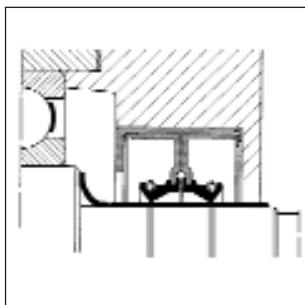
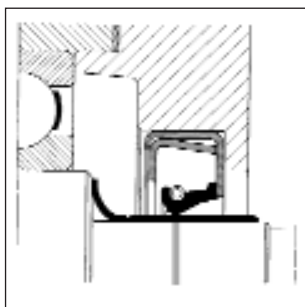

For shaft seals to perform efficiently, the condition of the shaft seating is of vital importance.

Preferably the surface should be hardened and ground without directional grooves. High pressures, temperatures and speeds, inadequate lubrication and solid contaminants all have a negative influence on sealing performance and also lead to grooving on the shaft.

In such cases, a simple seal replacement will not solve the problem, and it is generally necessary to rework the shaft. Such reworking is time consuming and costly. Wear sleeves have been designed to eliminate the need for reworking.

They are simply pushed over the damaged surface, enabling the shaft to be re-used within minutes - and at a fraction of the cost of traditional reworking.

Speedi-sleeves are made of stainless steel and have a wall thickness of 0,254 mm (0.01 inch).

Because of the thickness, the diameter of the seal seating will only be increased by about 0.5 mm so that it is possible to use replacement seals of the same size as the original one.

All speedi-sleeves have a removable installation flange at one side, for easy mounting together with the mounting tool supplied with each sleeve.

The flange can be removed easily as a pre-cut tear groove is provided.



SPEEDI-SLEEVE MEASUREMENT TABLE

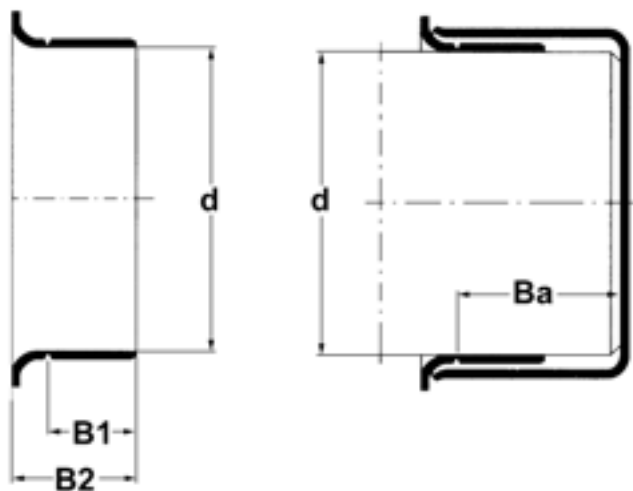

DIA. d	REF	B1	DIA. d	REF	B1
20	107TA5855		65	107TA5892	
22,23	107TA5856		66,68	107TA5893	12,7
25	107TA5857		66,68	107TA5894	19,8
25,4	107TA5858				
27	107TA5859		69,85	107TA5895	
28	107TA5860		70	107TA5896	
28,58	107TA5861		73,03	107TA5897	
30	107TA5862		75	107TA5898	
31,8	107TA5863		76,2	107TA5899	20,6
32	107TA5864				
33,35	107TA5865		76,2	107TA5900	15,9
34,01	107TA5866		79,38	107TA5901	
34,93	107TA5867	12,7	80	107TA5902	
34,93	107TA5868	13	82,55	107TA5903	
36,6	107TA5869		82	107TA5904	
38,1	107TA5870		84,07	107TA5905	
40,08	107TA5871		88,9	107TA5906	
41,28	107TA5872		90	107TA5907	
			91,97	107TA5908	
41,9	107TA5873				
44,45	107TA5874		92,08	107TA5909	
45	107TA5875				
46,05	107TA5876		95,25	107TA5910	
47,63	107TA5877				
48,03	107TA5878				
48,56	107TA5879		95	107TA5911	
49,23	107TA5880		100	107TA5912	
50	107TA5881		101,6	107TA5913	
50,8	107TA5882		107,95	107TA5914	
52,4	107TA5883		109,93	107TA5915	
53,98	107TA5884		111,13	107TA5916	
55	107TA5885		114,3	107TA5917	
55,58	107TA5886		120	107TA5918	
57,15	107TA5887		120,65	107TA5919	
60	107TA5888		127	107TA7678	
60,33	107TA5889		133,35	107TA5920	
61,93	107TA5890		152,4	107TA5921	
63,5	107TA5891				

OTHER DIMENSIONS AVAILABLE

SPEEDI-SLEEVE®

PAPER GASKET ROLLS



1 m x 45 cm
thickness: 0,4 mm
REF 105TA2757

1 m x 45 cm
thickness : 0,8 mm
REF 105TA2758



CYLINDER BUSHINGS



- METAL
- BRONZE
- COPPER
- STEEL
- TEFLON
- SELF-LUBRICATING
- PLASTIC

**COMPLETE RANGE OF BUSHINGS
AVAILABLE IN DIFFERENT MATERIALS**

Please indicate:

- inner diameter
- outer diameter
- length
- material

TECHNICAL DETAIL: BUSHING



FAX FORM: BUSHING

EXAMPLE



Company:

Customer code:

Name:

Fax number:

Truck make:

Truck type: Serial nr:

- . TY-BU..... bushing type, see pictures
- . TY-SL type of washer lock **NONE** - don't fill out
S - split bushing
R - roller bushing
- D1 dimensions, see pictures
- D2 dimensions, see pictures
- D3 dimensions, see pictures
- L total height of bushing
- S width of the collar, measured at the end of the collar
- ... MT-BU material bushing, "outer", see list
- ... MT-IN..... material bushing, "inner", see list
- . AT-GA..... number of grease holes - can also be an elliptical hole
- INW-GR..... inner grooves, see picture
- UITW-GR..... outer grooves, see picture
- ... DUIM YES : bushing in inches
..... NO : bushing in millimetres



ATTENTION : all dimensions on the detail list are in mm.

TYPE A

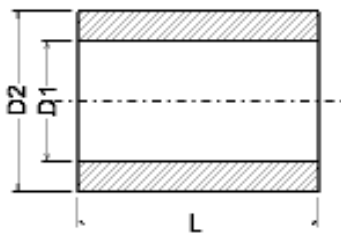

bushing without collar

TYPE B

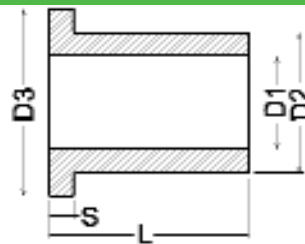

bushing with collar

TECHNICAL DETAIL: BUSHING

LIST OF MATERIALS, INTERNAL, EXTERNAL

- AL = aluminum
- BR = bronze
- BRZ = bronze self-lubricating
- CM = copper, brass
- CU = copper
- FI = fibre
- IX = stainless
- KS = synthetic
- MG = brass graphite
- MS = brass
- NY = nylon
- ST = steel, metal
- STG = steel, metal grinded
- STZ = steel, self-lubricating
- TF = teflon
- VU = urethane

ATTENTION :

- The internal material type only needs to be filled out when different from the external material.
- For material types applied in pastille shape we add a P
e.g. : TFP -> teflon pastille shape
CUP -> copper pastille shape

SCHEME GREASE GROOVES

RA

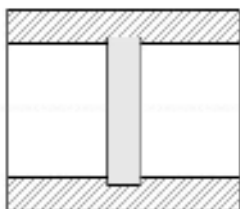

radial groove

AX

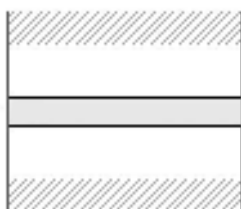

axial groove

SH

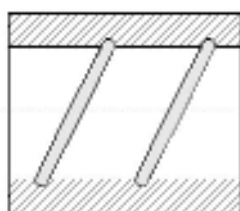

inclined groove

SP

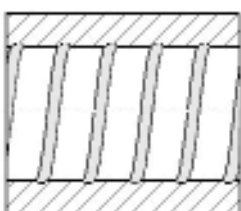













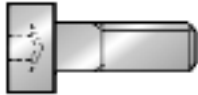



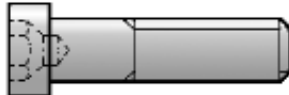











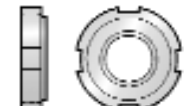

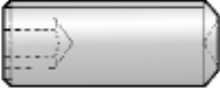



spiral groove

In case of different types of mixed grease grooves
RA -> AX -> SH -> SP

Behind the type we mark the number of existing grooves:
e.g. RA1 SH2 = 1 radial en 2 inclined grooves

If the grease grooves in the bushing are symmetrically divided, we define the number of grooves in one half of the bushing.
If not symmetrically divided, we define all internal grooves.

DIN NORMS FASTENING MATERIALS

 <p>DIN 931 - DIN 960 Hexagon head bolts</p>	 <p>DIN 933 - DIN 961 Hexagon head screws</p>	 <p>DIN 912 - Hexagon socket head cap screws</p>	 <p>DIN 6921 Hexagon flange bolts</p>
 <p>DIN 85 Slotted pan head screws</p>	 <p>DIN 7984 - Hexagon socket head cap screws with low head</p>	 <p>DIN 6912 - hexagon socket head cap screws with centre hole</p>	 <p>DIN 7991 - Hexagon socket countersunk head screws</p>
 <p>DIN 84 - Slotted cheese head screws</p>	 <p>DIN 963 - Slotted countersunk head screws</p>	 <p>DIN 7604 Hexagon head screw plugs</p>	 <p>DIN 906 Hexagon socket pipe plugs</p>
 <p>DIN 910 Hexagon head screw plugs</p>	 <p>DIN 908 Hexagon socket screw plugs</p>	 <p>DIN 935 Hexagon castle nut nuts</p>	 <p>DIN 6926 Hexagon flange nuts</p>
 <p>DIN 985 - Prevailing torque hexagon nuts</p>	 <p>DIN 934 Hexagon nuts</p>	 <p>DIN 315 Wing nuts</p>	 <p>DIN 1804 - Slotted round nuts for hook spanners</p>
 <p>DIN 939 Studs</p>	 <p>DIN 916 Hexagon socket screws</p>	 <p>DIN 660 Round head rivets</p>	 <p>DIN 6888 Woodruff keys</p>
 <p>DIN 94 Split pins</p>	 <p>NMG 475 Spring cotters</p>	 <p>DIN 1481 Spring pins</p>	 <p>DIN 127 Spring lock washers</p>
 <p>DIN 125 Washers</p>	 <p>DIN 6797 - Lock washers external teeth</p>	 <p>DIN 137 Wave spring washers</p>	 <p>DIN 137A Curved spring lock washers</p>
 <p>DIN 93 Tab washers with long tab</p>	 <p>DIN 6768A Lock washers</p>	 <p>DIN 472 Retaining rings for bores</p>	 <p>DIN 471 Retaining rings for shafts</p>





ZINC PLATED FASTENING HARDWARE

HARDWARE SET

High quality
Fastening hardware

REF/box	Size	Qty/box
 <p>Hexagon head screw & hex. nut 8.8 Din 933/934</p>		
124TA1745	M 3 x 16	15 pieces/box
124TA1746	M 3 x 20	14 pieces/box
124TA1747	M 4 x 16	12 pieces/box
124TA1748	M 4 x 20	11 pieces/box
124TA1749	M 4 x 30	10 pieces/box
124TA1750	M 5 x 16	17 pieces/box
124TA1751	M 5 x 20	16 pieces/box
124TA1752	M 5 x 25	15 pieces/box
124TA1753	M 5 x 30	14 pieces/box
124TA1754	M 6 x 16	15 pieces/box
124TA1755	M 6 x 20	14 pieces/box
124TA1756	M 6 x 30	12 pieces/box
124TA1757	M 6 x 40	10 pieces/box
124TA1758	M 6 x 50	8 pieces/box
124TA1759	M 6 x 80	8 pieces/box
124TA1760	M 8 x 20	8 pieces/box
124TA1761	M 8 x 30	7 pieces/box
124TA1762	M 8 x 40	6 pieces/box
124TA1763	M 8 x 50	5 pieces/box
124TA1764	M 8 x 60	4 pieces/box
124TA1765	M 10 x 30	11 pieces/box
124TA1766	M 10 x 40	9 pieces/box
124TA1767	M 10 x 50	8 pieces/box
124TA1768	M 10 x 60	7 pieces/box
124TA1769	M 10 x 70	6 pieces/box
124TA1770	M 10 x 80	5 pieces/box
124TA1771	M 10 x 100	4 pieces/box
124TA1772	M 12 x 30	6 pieces/box
124TA1773	M 12 x 40	6 pieces/box
124TA1774	M 12 x 50	6 pieces/box
124TA1775	M 12 x 60	6 pieces/box
124TA1776	M 14 x 30	6 pieces/box
124TA1777	M 14 x 40	6 pieces/box
124TA1778	M 14 x 50	6 pieces/box
124TA1779	M 14 x 60	6 pieces/box
124TA1780	M 16 x 40	5 pieces/box
124TA1781	M 16 x 50	5 pieces/box
124TA1782	M 16 x 60	5 pieces/box
124TA1783	M 16 x 80	5 pieces/box
124TA1784	M 20 x 50	5 pieces/box
124TA1785	M 20 x 60	5 pieces/box
124TA1786	M 20 x 80	5 pieces/box

 <p>Hexagon domed cap nuts class 6 Din 1587</p>		
124TA1852	M 4	7 pieces/box
124TA1853	M 5	6 pieces/box
124TA1854	M 6	5 pieces/box
124TA1855	M 8	3 pieces/box
124TA1856	M 10	2 pieces/box

REF/box	Size	Qty/box
 <p>Hex. socket screw 8.8 Din 912</p>		
124TA1787	M 4 x 16	12 pieces/box
124TA1788	M 4 x 20	11 pieces/box
124TA1789	M 4 x 30	10 pieces/box
124TA1790	M 5 x 16	17 pieces/box
124TA1791	M 5 x 20	16 pieces/box
124TA1792	M 5 x 30	14 pieces/box
124TA1793	M 6 x 16	15 pieces/box
124TA1794	M 6 x 20	14 pieces/box
124TA1795	M 6 x 30	12 pieces/box
124TA1796	M 6 x 40	10 pieces/box
124TA1797	M 8 x 20	8 pieces/box
124TA1798	M 8 x 30	7 pieces/box
124TA1799	M 8 x 40	6 pieces/box
124TA1800	M 10 x 30	7 pieces/box
124TA1801	M 10 x 40	6 pieces/box
124TA1802	M 10 x 50	5 pieces/box

 <p>Hexagon socket screw 10.9 Din 7991</p>		
124TA1803	M 4 x 16	12 pieces/box
124TA1804	M 4 x 20	11 pieces/box
124TA1805	M 4 x 30	10 pieces/box
124TA1806	M 5 x 16	17 pieces/box
124TA1807	M 5 x 20	16 pieces/box
124TA1808	M 5 x 30	14 pieces/box
124TA1809	M 6 x 16	15 pieces/box
124TA1810	M 6 x 20	14 pieces/box
124TA1811	M 6 x 30	12 pieces/box
124TA1812	M 6 x 40	10 pieces/box
124TA1813	M 8 x 20	8 pieces/box
124TA1814	M 8 x 30	7 pieces/box
124TA1815	M 8 x 40	6 pieces/box
124TA1816	M 10 x 30	5 pieces/box
124TA1817	M 10 x 40	4 pieces/box
124TA1818	M 10 x 50	3 pieces/box

 <p>Hexagon nut class 8 Din 934</p>		
124TA1832	M 3	35 pieces/box
124TA1833	M 4	30 pieces/box
124TA1834	M 5	25 pieces/box
124TA1835	M 6	22 pieces/box
124TA1836	M 8	13 pieces/box
124TA1837	M 10	7 pieces/box
124TA1838	M 12	5 pieces/box
124TA1839	M 14	3 pieces/box
124TA1840	M 16	6 pieces/box
124TA1841	M 18	4 pieces/box
124TA1842	M 20	4 pieces/box





ZINC PLATED FASTENING HARDWARE

REF/box	Size	Qty/box
 <p>Machine screw pan head Din 84/934</p>		
124TA1819	M 3 x 10	23 pieces/box
124TA1820	M 3 x 16	18 pieces/box
124TA1821	M 3 x 20	18 pieces/box
124TA1822	M 4 x 20	13 pieces/box
124TA1823	M 4 x 25	12 pieces/box
124TA1824	M 4 x 30	11 pieces/box
124TA1825	M 5 x 20	8 pieces/box
124TA1826	M 5 x 25	7 pieces/box
124TA1827	M 5 x 30	11 pieces/box
124TA1828	M 5 x 40	9 pieces/box
124TA1829	M 6 x 30	11 pieces/box
124TA1830	M 6 x 40	7 pieces/box
124TA1831	M 6 x 50	8 pieces/box

 <p>Hexagon locknut class 6 Din 985</p>		
124TA1843	M 3	14 pieces/box
124TA1844	M 4	12 pieces/box
124TA1845	M 5	10 pieces/box
124TA1846	M 6	8 pieces/box
124TA1847	M 8	7 pieces/box
124TA1848	M 10	5 pieces/box
124TA1849	M 12	4 pieces/box
124TA1850	M 14	5 pieces/box
124TA1851	M 16	5 pieces/box

 <p>Plain washer Din 125A</p>		
124TA1857	M 3 x 3,2	50 pieces/box
124TA1858	M 4 x 4,3	40 pieces/box
124TA1859	M 5 x 5,3	35 pieces/box
124TA1860	M 6 x 6,4	30 pieces/box
124TA1861	M 8 x 8,4	20 pieces/box
124TA1862	M 10 x 10,5	12 pieces/box
124TA1863	M 12 x 13,0	7 pieces/box
124TA1864	M 14 x 15,0	6 pieces/box
124TA1865	M 16 x 17,0	5 pieces/box
124TA1866	M 18 x 19,0	4 pieces/box
124TA1867	M 20 x 21,0	3 pieces/box

 <p>Flat washer Din 9021</p>		
124TA1868	M 5 x 15/ 5,3	22 pieces/box
124TA1869	M 5 x 20/ 5,3	14 pieces/box
124TA1870	M 6 x 18/ 6,4	18 pieces/box
124TA1871	M 6 x 25/ 6,4	11 pieces/box
124TA1872	M 6 x 30/ 6,4	8 pieces/box
124TA1873	M 8 x 20/ 8,5	8 pieces/box
124TA1874	M 8 x 25/ 8,5	8 pieces/box
124TA1875	M 8 x 30/ 8,5	8 pieces/box
124TA1876	M 8 x 36/ 8,5	8 pieces/box
124TA1877	M 10 x 30/10,5	5 pieces/box
124TA1878	M 10 x 36/10,5	4 pieces/box
124TA1879	M 12 x 37/12,5	4 pieces/box
124TA1880	M 14 x 40/14,5	4 pieces/box

REF/box	Size	Qty/box
 <p>Spring lock washer Din 127B</p>		
124TA1881	M 4	35 pieces/box
124TA1882	M 5	30 pieces/box
124TA1883	M 6	25 pieces/box
124TA1884	M 8	22 pieces/box
124TA1885	M 10	15 pieces/box
124TA1886	M 12	10 pieces/box
124TA1887	M 14	7 pieces/box
124TA1888	M 16	5 pieces/box

 <p>External serrated lock washer Din 6798A</p>		
124TA1889	M 4	35 pieces/box
124TA1890	M 5	25 pieces/box
124TA1891	M 6	20 pieces/box
124TA1892	M 8	20 pieces/box
124TA1893	M 10	19 pieces/box
124TA1894	M 12	13 pieces/box
124TA1895	M 14	8 pieces/box
124TA1896	M 16	6 pieces/box

 <p>Selfdrilling screw hexagon head Din 7504K</p>		
124TA1897	3,5 x9,5	25 pieces/box
124TA1898	3,5 x 13	24 pieces/box
124TA1899	3,5 x 16	22 pieces/box
124TA1900	3,5 x 19	20 pieces/box
124TA1901	4,2 x 13	22 pieces/box
124TA1902	4,2 x 16	20 pieces/box
124TA1903	4,2 x 19	19 pieces/box
124TA1904	4,2 x 25	17 pieces/box
124TA1905	4,8 x 16	15 pieces/box
124TA1906	4,8 x 19	14 pieces/box
124TA1907	4,8 x 25	13 pieces/box
124TA1908	4,8 x 32	12 pieces/box
124TA1909	5,5 x 25	10 pieces/box
124TA1910	5,5 x 32	9 pieces/box
124TA1911	5,5 x 38	8 pieces/box

 <p>Cotter pins Din 94</p>		
124TA1912	1,6 x 20	25 pieces/box
124TA1913	2,0 x 25	17 pieces/box
124TA1914	2,5 x 32	12 pieces/box
124TA1915	3,2 x 40	14 pieces/box
124TA1916	4,0 x 50	10 pieces/box
124TA1917	5,0 x 63	6 pieces/box

COUNTERSUNK SCREWS & NUTS



REF 107TA5446

840 Pieces
bicro zinc
Din 965 + 934
M3 x 8
M4 x 20
M5 x 25
M3 x 20
M4 x 40
M5 x 50

SOCKET SET SCREWS



REF 107TA5445

250 pieces
Black sink
Metric - DIN 916
M4 x 8 - M5 x 5
M5 x 10 - M6 x 6
M6 x 8 - M6 x 10
M8 x 8 - M8 x 10
M8 x 12 - M10 x 10

SOCKET HEAD CAP SCREWS



REF 107TA5444

100 pieces
Metric - Black
DIN 912 12.9
M5 x 30 - M5 x 40
M6 x 30 - M6 x 40
M8 x 30 - M8 x 40
M10 x 10 - M10 x 40

NUTS



REF 107TA5443

2200 pieces
Metric
bicro zinc
Din 934
M5
M6
M8
M10

COUNTERSUNK SERRATED LOCK WASHERS



REF 107TA5442

1000 pieces
zinc
DIN 6798
M5
M6
M8
M10
M11
M13

SPRING PINS



REF 107TA5441

185 pieces
metric
M3 x 25 M3 x 40
M4 x 25 M4 x 40
M5 x 25 M5 x 40
M6 x 25 M6 x 40
M8 x 25 M8 x 40
M10 x 24 M10 x 40

HARDWARE SETS

RETAINING RINGS



REF 107TA5452

280 pieces
Internal and external circlips
DIN 472 and DIN 471

8	9	10
11	12	13
14	15	16

SEALING RINGS - COPPER



REF 107TA5451

250 pieces
DIN 7603A - 16 sizes

M5 x 9 x 1	M6 x 10 x 1
M6 x 12 x 1	M8 x 12 x 1
M8 x 14 x 1	M10 x 14 x 1
M 10 x 16 x 1	M12 x 16 x 1.5
M12 x 18 x 1.5	M14 x 18 x 1.5
M14 x 20 x 1.5	M16 x 20 x 1.5
M16 x 22 x 1.5	M18 x 22 x 1.5
M18 x 24 x 1.5	M20 x 26 x 1.5

SPRING PINS



REF 107TA5450

300 pieces
Metric 2.5 x 24 2.5 x 40

3 x 24	3 x 40
4 x 24	4 x 40
5 x 24	5 x 40
6 x 24	6 x 40
8 x 24	8 x 55

SEALING RINGS - COPPER



REF 107TA5449

645 pieces
copper-ceramic
12 sizes

6 x 10 x 1,5
8 x 12 x 1,5
8 x 14 x 1,5
12 x 16 x 2
14 x 18 x 2
14 x 20 x 2
16 x 22 x 2
18 x 28 x 2
20 x 26 x 2
24 x 32 x 2,5
26 x 32 x 2,5
32 x 38 x 2,5

SEALING RINGS - COPPER



REF 107TA5448

475 pieces

3/16 x 7/16
1/4 x 9/16
5/16 x 5/8
3/8 x 3/4
7/16 x 7/8
1/2 x 1

STEEL PLATE SCREWS



REF 107TA5447

315 pieces
AB type DIN 7971 1/C

4.8 x 13	4.8 x 19
4.8 x 25	4.8 x 38
5.5 x 19	5.5 x 25
5.5 x 38	6.3 x 25
6.3 x 38	

STEEL PLATE SCREWS



REF 107TA5458

700 pieces
split bent head
AB type DIN 7971/C
2.9 x 13 3.5 x 13
3.5 x 19 4.2 x 13
4.2 x 19 4.2 x 25
4.8 x 13 4.8 x 19
4.8 x 25 5.5 x 19
5.5 x 25

STEEL PLATE SCREWS



REF 107TA5457

615 pieces
Countersunk head
AB type DIN 7982/C/Z
3.5 x 19 3.5 x 25
3.5 x 38 4.2 x 19
4.2 x 25 4.2 x 38
4.8 x 19 4.2 x 25
4.8 x 38

TAPERED SCREWS



REF 107TA5456

700 pieces
AB type Din 7981/C/Z
2.9 x 13 3.5 x 13
3.5 x 19 4.2 x 13
4.2 x 19 4.2 x 25
4.8 x 13 4.8 x 19
4.8 x 25 5.5 x 19
5.5 x 25

NUTS WITH PLASTIC INSERT



REF 107TA5455

300 pieces
DIN 982
M6
M8
M10
M12

LOCK WASHERS



REF 107TA5454

1015 pieces
Metric
DIN 127B
M5 - M6
M8 - M10
M12 - M16
M20

LUBRICATING NIPPLES



REF 107TA5453

115 pieces
Metric
M6x1-45°-90°-180°
M8x1-180°
M8x1,25-45°-90°-180°
M10x1-180°
M10x1,5-180°

ASSORTMENT FIBER RINGS



REF 123TA8016

	Qty		Qty
5 x 8 x 1	200	14 x 18 x 1	75
6 x 9 x 1	200	15 x 19 x 1	75
7 x 10 x 1	200	16 x 21 x 1	70
8 x 12 x 1	150	17 x 22 x 1	70
9 x 14 x 1	150	18 x 24 x 1	65
10 x 14 x 1	150	19 x 23 x 1	65
11 x 17 x 1	100	20 x 24 x 1	60
12 x 16 x 1	100	22 x 26 x 1	40
12,5 x 18 x 1	100	24 x 28 x 1	40

ASSORTMENT TENSION SPRINGS



REF 123TA8017

	Qty
0,5 x 4,5 x 20	50
0,5 x 6,5 x 20	24
0,5 x 6,5 x 30	20
0,8 x 6,7 x 35	20
0,8 x 6,7 x 40	15
0,8 x 7,7 x 50	12
1 x 10 x 40	10
1 x 10 x 60	8
1,5 x 10 x 50	6

ASSORTMENT LOCKRINGS



REF 123TA8018

	Qty
1,5	60
1,9	78
2,3	80
3,2	80
4	68
5	53
6	42
7	40
8	30



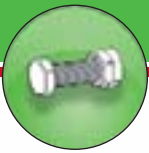

ASSORTMENT SPEEDNUTS & SPEEDCYLINDERS



REF 123TA8019

	Qty
3 mm	55
4 mm	35
5 mm	32
6 mm	25
M3 5020	40
M4 5021	37
2 mm 5011	72
3 mm 0211	50
4 mm 0212	40

Qty

5 mm 0213	30
5,5 mm 0178	20
2,5 mm 1722	60
3,5 mm 1212	40
M6	5
M8	5
M4 4828	5
M5 4825	5
M6 4826	5

HARDWARE SETS

ASSORTMENT TENSION SPRINGS



REF 123TA8020

	Qty
0,5 x 6,5 x 30	20
0,8 x 7,7 x 35	20
0,8 x 7,7 x 50	15
1 x 8 x 30	16
1 x 10 x 60	9
1,5 x 10 x 50	10
1,5 x 12 x 40	6
1,5 x 14 x 60	5
2 x 14 x 50	5

ASSORTMENT LOCKNUTS



REF 123TA8021

	Qty
3 mm	50
4 mm	40
5 mm	40
6 mm	30
8 mm	30
10 mm	20
12 mm	17
16 mm	10
20 mm	5

ASSORTMENT HEXAGON BOLTS & NUTS UNF



REF 123TA8023

	Qty
1/4X5/8 1/4	10
1/4X3/4 1/4	10
1/4X1 1/4	10
1/4X1.1/4 1/4	9
5/16X1 5/16	7
5/16X1.1/2 5/16	6
3/8X1 3/8	5
3/8X1.1/2 3/8	4
1/2X1.1/4 1/2	2



ASSORTMENT HALF-ROUND WEDGES



REF 123TA8024	Qty
2 x 2.6	37
2 x 3.7	32
2 x 5	28
2.5 x 3.7	27
3 x 3.7	28
3 x 5	24
3 x 6.5	20
3 x 7.5	20
4 x 5	20

ASSORTMENT RECTANGULAR WEDGES



REF 123TA8025	Qty
5 x 5 x 20	16
5 x 5 x 32	13
5 x 5 x 40	12
6 x 6 x 20	16
6 x 6 x 32	9
8 x 7 x 40	9
8 x 7 x 50	7
10 x 8 x 50	5
10 x 8 x 63	3

ASSORTMENT SPLIT PINS



REF 123TA8026	Qty	Qty	
2 x 20	250	4 x 40	100
2 x 40	200	4 x 50	75
2,5 x 32	200	5 x 40	50
2,5 x 40	150	5 x 50	40
3,2 x 40	125	6,3 x 63	30
3,2 x 50	100	6,3 x 80	25

ASSORTMENT STOPPERS



REF 123TA8027	Qty	Qty	
M10 x 1 DIN 908	15	M16 x 1,5 DIN 910	10
M12 x 1,5 DIN 908	10	M18 x 1,5 DIN 910	5
M14 x 1,5 DIN 908	10	M20 x 1,5 DIN 910	5
M10 x 1 DIN 910	15	M22 x 1,5 DIN 908	3
M12 x 1,5 DIN 910	10	M24 x 1,5 DIN 908	3
M14 x 1,5 DIN 910	10	M30 x 1,5 DIN 908	2
M16 x 1,5 DIN 908	10	M22 x 1,5 DIN 910	3
M18 x 1,5 DIN 908	5	M24 x 1,5 DIN 910	3
M20 x 1,5 DIN 908	5	M30 x 1,5 DIN 910	2





SPLIT PINS



REF 107TA5462

1000 pieces
 Size Imperial & Metric
 1/16 x 1 5/64 x 1
 3/32 x 1 3/32 x 1
 7/64 x 1 1/8 x 1
 9/64 x 1 5/32 x 1 5/8
 1.6 - 2 - 2.5 - 2.8 - 3.2 - 3.6 - 4 mm

EMPTY ASSORTMENT BOXES



REF 107TA5461

L 260 x W 160 x H 40 mm
 12 compartments of 60 x 50 mm

HARDWARE SETS AND BOXES

CARTON STORAGE BOXES

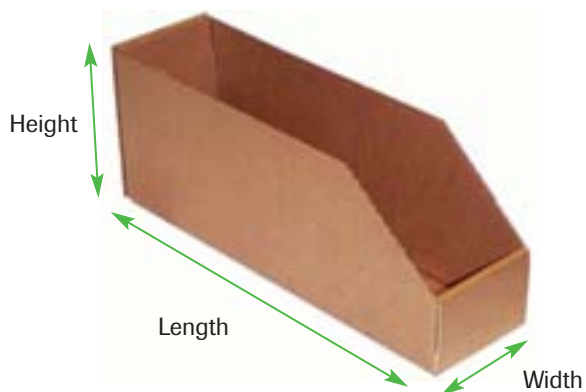

Length	width	height	REF
390 mm	50 mm	150 mm	107TA5463
390	100	150	107TA5464
390	200	150	107TA5465
390	300	150	107TA5466

Thickness of carton = 3 mm

DOUBLE SIDED POLYPROPYLENE STORAGE BOXES

REF 121TA1107

590 x 100 x 130 mm

REF 121TA1108

590 x 200 x 130 mm

REF 121TA1109

590 x 50 x 130 mm



THREAD GAUGE



REF 107TA5460

Metric and Imperial

EMPTY ASSORTMENT BOXES

REF 107TA5459

18 x (50 x 50 mm) height = 30 mm
 9 x (50 x 100 mm) height = 30 mm
 6 x (50 x 100 mm) height = 60 mm
 3 x (100 x 100 mm) height = 60 mm
 2 x (100 x 150 mm) height = 60 mm
 1 x (90 x 310 mm) height = 90 mm



TECHNICAL DETAIL: SPRINGS



EXTENSION SPRING

- D1: OUTER DIA.
- D2: WIRE DIAMETER
- L1: LENGTH BETWEEN THE HOOKS
- TYPE:

TYPE A

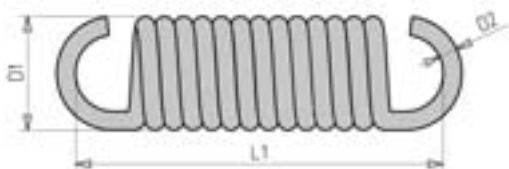

TYPE B



TYPE S

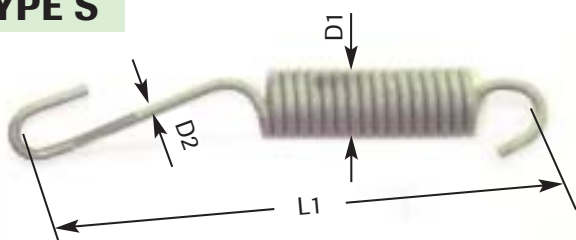

TYPE R

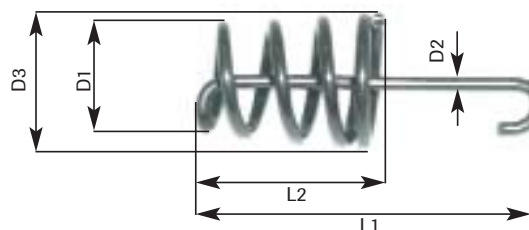

COMPRESSION SPRING

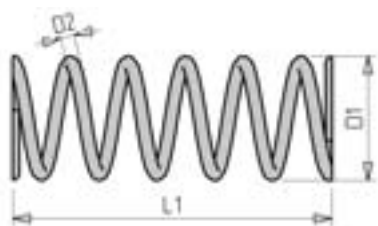

- D1: OUTER DIA.
- L1: TOTAL LENGTH
- D2: WIRE DIAMETER

Company:

Customer code:

Name:

Fax number:

Truck make:

Truck type: Serial nr:



COTTER PIN GRADE 2



COTTER PINS

DIMENSIONS

D..... DIAMETER

L LENGTH



COTTER PIN GRADE 2

length	Ø 1	Ø 1,6	Ø 2	Ø 2,5	Ø 3,2	Ø 3,5	Ø 4	Ø 4,5	Ø 5	Ø 6,3	Ø 8	Ø 10	Ø 13
10	105TA2505	105TA2466	107TA7788	105TA2518	105TA2552		105TA2606	105TA2596					
12	107TA5478	107TA5467	107TA5469	105TA2519	105TA2553		107TA5482						
16	105TA2507	105TA2468	105TA2536	107TA5474	105TA2556		107TA5483	105TA2597					
20	105TA2509	105TA2470	107TA5470	107TA5475	105TA2558	107TA5479	105TA2610	105TA2598	105TA2635				
25	105TA2510	105TA2472	105TA2541	105TA2524	105TA2560	107TA5480	105TA2612	105TA2599	107TA5493	107TA5500			
32	105TA2511	105TA2474	107TA5471	105TA2528	105TA2585	105TA2572	107TA5484		107TA5494	105TA2659			
40	105TA2514	105TA2477	107TA5472	107TA5476	107TA5477	107TA5481	107TA5485	107TA5491	107TA5495	105TA2661	105TA2704		
50	105TA2516	105TA2478	107TA5473	105TA2531	105TA2590	107TA5487	105TA2620	105TA2602	107TA5496	107TA5501	107TA5509	107TA5512	
63			105TA2550	105TA2532	105TA2566	107TA5488	127TA3162	107TA5492	107TA5492	107TA5502	127TA3163	105TA2492	
71						107TA5489	107TA5486	107TA5486	107TA5497	107TA5503	107TA5510	105TA2493	
80							105TA2626	105TA2604	107TA5498	107TA5504	105TA2710	107TA5513	
90							105TA2627	105TA2605	107TA5499	107TA5505	107TA5511	107TA5514	
100										107TA5506	105TA2698	107TA5515	105TA2497
112										107TA5507	105TA2699	105TA2483	105TA2498
125										107TA5508	105TA2700	105TA2485	105TA2499
140											105TA2701	105TA2487	105TA2500
160											105TA2702	107TA5516	107TA5517

LINCH PIN



dia. (mm)	REF
4,5	106TA6975
6	106TA6976
7	106TA6977
8	106TA6978
9,5	106TA6979
10	106TA6980
11	106TA6981

SPRING COTTER



dia. (mm)	REF
2,5	106TA6982
3,5	106TA6983
4,5	106TA6984
6	106TA6985
7	106TA6986
8	106TA6987

HEAVY DUTY SPRING COTTER



dia. (mm)	REF
3,5	106TA6988
5,5	106TA6989

STANDARD EXHAUST CLAMPS



Diameter (mm)		Tube diameter (mm)		REF
(mm)	(inch)	(mm)	(inch)	
35	1" 3/8	31,75	1" 1/4	107TA1895
38	1" 1/2	34,93	1" 3/8	107TA1896
41	1" 5/8	38,10	1" 1/2	107TA1897
44	1" 3/4	41,28	1" 5/8	107TA1898
48	1" 7/8	44,45	1" 3/4	107TA1899
51	2"	47,63	1" 7/8	107TA1900
54	2" 1/8	50,80	2"	107TA1901
58	2" 1/4	53,98	2" 1/8	107TA1902
60	2" 3/8	57,15	2" 1/4	107TA1903
67	2" 5/8	63,50	2" 1/2	107TA1904
73	2" 7/8	69,85	2" 3/4	107TA1905
79	3" 1/8	76,20	3"	107TA1906
105	4" 1/8	101,6	4"	107TA1907



CLAMPS

HEAVY-DUTY EXHAUST CLAMPS

	Diameter		REF
	(mm)	(inch)	
	54	2" 1/8	107TA1888
	67	2" 5/8	107TA1889
	73	2" 7/8	107TA1890
	79	3" 1/8	107TA1891
	86	3" 3/8	107TA1892
	92	3" 5/8	107TA1893
	113	4" 7/16	107TA1894

JUBILEE CLIPS

	min.	max.	min.	max.	REF
	(mm)		(inch)		
	6	16	0,22	0,62	106TA2821
	10	19	0,44	0,78	106TA2822
	18	31	0,69	1,25	106TA2823
	21	44	0,81	1,75	106TA2824
	40	63	1,56	2,50	106TA2825
	52	76	2,06	3,00	106TA2826
	71	95	2,81	3,75	106TA2827
	90	114	3,56	4,50	116TA5593
	109	133	4,31	5,25	106TA2829
	130	152	5,12	6,00	106TA2830
	150	171	5,88	6,75	106TA2831

JUBILEE CLIP WITH PLASTIC KEY

	dia. (mm)	dia. (mm)	REF
	min	max	
	8	12	106TA7861
	10	16	106TA7862
	12	22	106TA7863
	16	27	106TA7864
	20	32	106TA7865
	25	40	106TA7866
	32	50	106TA7867
	40	60	106TA7868

GREASE NIPPLES



	M6X1	M8X1	M10X1	1/8 inch	1/4 inch
right	REF 107TA5528	REF 107TA5529	REF 107TA5530	REF 107TA5531	REF 107TA5532
45°	REF 107TA5533	REF 107TA5534	REF 107TA5535	REF 107TA5536	REF 107TA5537
90°	REF 107TA5543	REF 107TA5541	REF 107TA5540	REF 107TA5539	REF 107TA5538

GREASE NIPPLE WITHOUT THREAD

	≥ 5	≥ 6
right	REF 107TA5544	REF 107TA5542

PROFESSIONAL CABLE TIES

Manufactured from flexible and durable nylon. For a quick and easy attachment of cables and other light components.



Width (mm)	Length (mm)	REF Packaging quant. White	REF Packaging quant. Black	Packaging quant.
2,5	98	111TA3872	111TA3884	100 pieces
3,6	140	111TA3873	111TA3885	100 pieces
4,5	160	111TA3874	111TA3886	100 pieces
4,8	200	111TA3875	111TA3887	100 pieces
4,8	280	111TA3876	111TA3888	100 pieces
4,8	360	111TA3877	111TA3889	100 pieces
4,8	178	111TA3878	111TA3890	100 pieces
7,8	360	111TA3879	111TA3891	100 pieces
7,8	540	111TA3880	111TA3892	100 pieces
12,6	500	111TA3881	111TA3893	50 pieces
12,6	730	111TA3882	111TA3894	50 pieces
12,6	1000	111TA3883	111TA3895	50 pieces

ADHESIVE CABLE TIE BASES (WITHOUT CABLE TIE)

cable tie bases : white (box of 100) REF 106TA9776

cable tie bases : black (box of 100) REF 106TA9777



Dimensions 30 x 25 mm

THREADED RODS

Dimensions

M 4 x 1000 mm
M 5 x 1000 mm
M 6 x 1000 mm
M 8 x 1000 mm
M 10 x 1000 mm
M 12 x 1000 mm
M 14 x 1000 mm
M 16 x 1000 mm
M 18 x 1000 mm
M 20 x 1000 mm

REF per m

107TA5518
107TA5519
107TA5520
107TA5521
107TA5522
107TA5523
107TA5524
107TA5525
107TA5526
107TA5527



Quality: 8.8

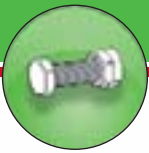

U-CUPS

Dia	REF	Dia	REF
8	107TA5635	7/16	103TA2324
10	103TA2268	1/2	107TA5626
12	103TA2270	9/16	103TA2326
14	107TA5636	19/32	103TA2279
15	103TA2273	3/4	107TA5627
16	107TA5637	13/16	103TA2271
17	107TA5638	7/8	103TA2325
18	107TA5639	15/16	107TA5628
20	103TA2286	1"	103TA2293
21	103TA2287	1"1/8	107TA5629
22	103TA2289	1"3/16	107TA5630
24	103TA2290	1"1/4	103TA2251
25	103TA2291	1"5/16	107TA5631
26	103TA2292	1"1/2	107TA5632
27	103TA2295	1"5/8	103TA2260
28	103TA2296	1"7/8	107TA5633
30	103TA2299	2"	103TA2280
32	107TA5640	2"1/4	103TA2281
34	107TA5641	2"3/8	103TA2282
35	107TA5642	2"1/2	107TA5634
36	103TA2304	2"7/8	103TA2283
37	103TA2305		
38	103TA2307		
40	103TA2309		
42	103TA2310		
44	103TA2311		
45	103TA2314		
47	103TA2316		
48	107TA5643		
50	103TA2318		
51	103TA2319		
55	103TA2321		



CUPS

BEND CUPS

Dia	REF	Dia	REF
8	103TA2384	3/8	103TA2370
12	103TA2346	7/16	103TA2344
14	103TA2348	1/2	103TA2344
15	103TA2349	9/16	103TA2400
16	107TA5619	5/8	103TA2385
18	103TA2351	11/16	103TA2345
20	103TA2361	3/4	103TA2369
21	103TA2362	13/16	103TA2347
22	103TA2363	7/8	103TA2398
25	103TA2364	15/16	103TA2350
28	103TA2366	1	103TA2327
30	103TA2371	1"1/16	103TA2328
32	103TA2372	1"1/8	103TA2332
33	103TA2373	1"3/16	103TA2335
34	103TA2374	1"1/4	103TA2331
35	103TA2375	1"5/16	103TA2339
36	107TA5620	1"3/8	103TA2337
38	103TA2377	1"7/16	103TA2341
39	103TA2378	1"1/2	103TA2329
40	103TA2379	1"9/16	103TA2343
42	107TA5621	1"5/8	103TA2340
45	103TA2382	1"11/16	103TA2333
48	103TA2383	1"47/64	107TA5615
50	107TA5622	1"3/4	103TA2336
51	103TA2387	1"7/8	107TA5616
52	107TA5623	1"15/16	103TA2334
55	107TA5624	2"	103TA2352
56	103TA2390	2"1/16	107TA5617
58	107TA5625	2"1/8	103TA2356
60	103TA2392	2"7/32	103TA2360
62	103TA2393	2"1/4	103TA2355
64	103TA2395	2"3/8	103TA2359
65	103TA2396	2"3/4	107TA5618
80	103TA2399	2"15/16	103TA2357
		3"	103TA2367
		3"1/4	103TA2368



CAPS WITH METRIC THREAD

Thread d1	D	h1	H	REF
M8	12	8	9	107TA5684
M10	14	8	9	107TA5685
M12	16	12	13.5	107TA5686
M14	18	12	13.5	107TA5687
M16	21	12	13.5	107TA5688
M18	22	12	13.5	107TA5689
M20	25	14	15.5	107TA5690
M22	28	14	15.5	107TA5691
M24	32	14	16	107TA5692
M27	35	14	16	107TA5693
M30	38	14	16	107TA5694
M 8 x 1	12	8	9	107TA5695
M 10 x 1	14	8	9	107TA5696
M 12 x 1	16	12	13.5	107TA5697
M 12 x 1.5	16	12	13.5	107TA5698
M 14 x 1.5	18	12	13.5	107TA5699
M 16 x 1.5	21	12	13.5	107TA5700
M 18 x 1.5	22	12	13.5	107TA5701
M 20 x 1.5	25	14	15.5	107TA5702
M 22 x 1.5	28	14	15.5	107TA5703
M 23 x 1.5	29	22	23	107TA5704
M 24 x 1.5	30	14	15.5	107TA5705
M 25 x 1.5	33	14	16	107TA5706
M 26 x 1.5	34	11	13	107TA5707
M 28 x 1.5	34.5	28	30	107TA5708
M 30 x 1.5	36	14	15.5	107TA5709
M 36 x 1.5	44	17	19	107TA5710
M 45 x 1.5	53	15	17	107TA5711
M 55 x 1.5	63	16	18	107TA5712
M 18 x 2	22	12	13.5	107TA5713
M 20 x 2	25	14	15.5	107TA5714
M 22 x 2	28	14	15.5	107TA5715
M 30 x 2	38	14	16	107TA5716
M 36 x 2	44	17	19	107TA5717
M 42 x 2	50	15	17	107TA5718
M 45 x 2	53	15	17	107TA5719
M 52 x 2	60	15	17	107TA5720

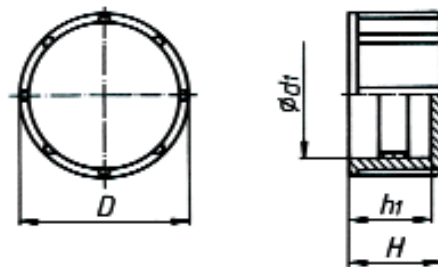

PLUGS WITH METRIC THREAD

Thread d1	D	h1	h2	REF
M6	12	7	5	107TA5644
M6 x 0.75	12	7	5	107TA5645
M8	12	7	5	107TA5646
M10	14	9	5	107TA5647
M12	16	9	5	107TA5648
M14	19	9	5	107TA5649
M16	21	10	6	107TA5650
M18	24	10	6	107TA5651
M20	26	12	6	107TA5652
M22	28	12	6	107TA5653
M24	32	10	8	107TA5654
M8 x 1	12	7	5	107TA5655
M10 x 1	14	9	5	107TA5656
M12 x 1	16	9	5	107TA5657
M14 x 1	19	9	5	107TA5658
M12 x 1.5	16	9	5	107TA5659
M14 x 1.5	19	9	5	107TA5660
M16 x 1.5	21	10	6	107TA5661
M18 x 1.5	24	10	6	107TA5662
M20 x 1.5	26	12	6	107TA5663
M22 x 1.5	28	12	6	107TA5664
M24 x 1.5	31.5	10	9	107TA5665
M26 x 1.5	31.5	12	9	107TA5666
M30 x 1.5	36	12	8	107TA5667
M34 x 1.5	42	13	10	107TA5668
M36 x 1.5	44	13	10	107TA5669
M42 x 1.5	52	15	10	107TA5670
M45 x 1.5	55	15	10	107TA5671
M52 x 1.5	60	15	10	107TA5672
M18 x 2	24	10	6	107TA5673
M20 x 2	26	12	6	107TA5674
M22 x 2	28	12	6	107TA5675
M24 x 2	31.5	10	8	107TA5676
M27 x 2	32	12	8	107TA5677
M30 x 2	36	12	8	107TA5678
M33 x 2	39	13	10	107TA5679
M36 x 2	44	13	10	107TA5680
M42 x 2	52	15	10	107TA5681
M45 x 2	55	15	10	107TA5682
M52 x 2	60	15	10	107TA5683

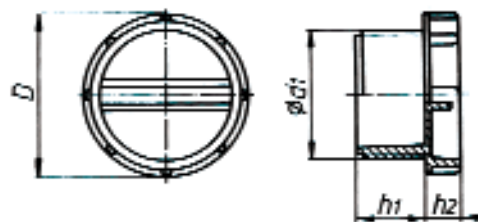



PLUGS WITH IMPERIAL THREAD

Thread d1	D	h1	h2	REF
1/4" - 18 NPTF	19	9	5	107TA7789
1/4" - 28 UNF	12	7	5	107TA7790
3/8" - 24 UNF	14	9	5	107TA8346
7/16" - 20 UNF	16	9	5	107TA7791
1/2" - 20 UNF	16	9	5	107TA7792
9/16" - 18 UNF	19	9	5	107TA7793
9/16" - 24 UNEF	19	9	5	107TA7794
5/8" - 18 UNF	21	10	6	107TA7795
5/8" - 24 UNEF	21	10	6	107TA7796
3/4" - 16 UNF	26	12	6	107TA7797
3/4" - 20 UNEF	24	16	6	107TA7964
7/8" - 9 UNC	28	12	6	107TA7799
7/8" - 14 UNF	28	12	6	107TA7800
15/16" - 20 UNEF	32	10	8	107TA7801
1" - 14 UNS	32	10	8	107TA7802
1" - 16 UN	32	12	8	107TA7803
1" 1/16 - 12 UN	32	12	8	107TA7965
1" 1/16 - 16 UN	32	12	8	107TA7805
1" 3/16" - 20 UN	36	12	8	107TA7806
1" 1/4" - 12 UNF	36	12	8	107TA7807
1" 5/16" - 12 UN	42	13	10	107TA7808
1" 3/8 - 18 UNEF	42	13	10	107TA7809
1" 7/16 - 18 UNEF	44	13	10	107TA7810
1" 5/8 - 12 UN	52	15	10	107TA7811
1" 5/8 - 16 UN	52	15	10	107TA7812
1" 3/4 - 16 UN	55	15	10	107TA7813
1" 13/16 - 16 UN	55	15	10	107TA7814
1" 7/8 - 12 UN	57	15	10	107TA7815
1" 7/8 - 18 UNS	57	15	10	107TA7816
2" 1/8 - 12 UN	62	15	10	107TA7817
2" 1/8 - 16 UN	62	15	10	107TA7818
2" 1/4 - 12 UN	65	15	10	107TA7819
2" 3/8 - 16 UN	72	18	12	107TA7820
2" 1/2 - 12 UN	72	18	12	107TA7821
2" 1/2 - 16 UN	72	18	12	107TA7822

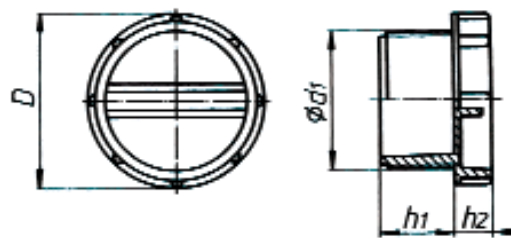

PLUGS AND CAPS WITH IMPERIAL THREAD

CAPS

D	d1	d2	d3	d4	h1	REF
10	4.4	6.15	4.55	2.8	10	107TA5721
11	6	7.75	6.15	4.4	10	107TA5722
13	7.6	9.35	7.75	6	10	107TA5723
14	8.4	10.15	8.55	6.8	10	107TA5724
14	9.2	10.95	9.25	7.5	10	107TA5725
15	9.9	11.65	10.05	8.3	10	107TA5726
16	10.6	12.35	10.75	9	10	107TA5727
17	11.3	13.05	11.2	9.5	10	107TA5728
18	12	14.1	12.5	10.4	12	107TA5729
18	12.5	14.6	13.3	11.2	12	107TA5730
19	13.5	15.6	14	11.9	12	107TA5731
19	14	16.1	14.5	12.4	12	107TA5732
21	14.7	17	15.5	13.2	13	107TA5733
22	16.3	18.6	17	14.7	13	107TA5734
22	17.1	19.4	17.8	15.5	13	107TA5735
24	17.5	20.1	18.5	15.9	15	107TA5736
25	18.4	21	19.4	16.8	15	107TA5737
25	19	21.6	20	17.4	15	107TA5738
27	20.4	23.2	21.6	18.8	16	107TA5739
28	20.7	23.5	21.9	19.1	16	107TA5740
29	22	24.8	23.2	20.4	16	107TA5741
30	23.2	26.35	24.35	21.2	18	107TA5742
32	24.5	27.8	26.2	22.9	19	107TA5743
33	25.2	29.2	27.7	23.7	19	107TA5744
33	26.4	30.4	28.9	24.9	19	107TA5745
35	27.8	31.1	29.5	26.2	19	107TA5746
37	29.8	32.6	31.1	28.3	16	107TA5747
38	31.4	35.1	33.4	29.7	21	107TA5748
41	33.3	37.1	35.5	31.7	22	107TA5749
45	36.7	40.5	39	35.2	22	107TA5750
45	38.4	40.7	39.2	36.9	13	107TA5751
48	38.2	43	41.4	36.6	23	107TA5752
48	39.6	42.9	41.9	38	19	107TA5753
49	41.4	44.7	43	39.7	19	107TA5754
51	44.4	47.7	46.1	42.8	19	107TA5755
54	45.2	49.6	48	43.6	25	107TA5756
55	46.6	51	49.6	45.2	25	107TA5757
62	52.5	56.9	55.2	50.8	25	107TA5758
65	54	59.25	57.75	52.5	25	107TA5759
65	54.2	58.6	57	52.6	25	107TA5760
67	58.4	62.8	61.1	56.7	25	107TA5761
71	60.7	67.1	64.3	59	29	107TA5762
75	67.1	70.4	68.7	65.4	19	107TA5763
83	72.4	75.7	74.1	70.8	19	107TA5764
92	84.5	87.8	85.7	82.4	19	107TA5765

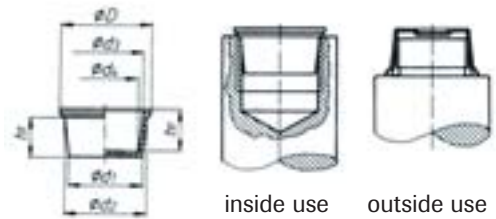

CAPS WITH IMPERIAL THREAD

Thread d1	D	h1	H	REF
1/4" -28 UNF	12	8	9	107TA5766
5/16" -24 UNF	12	8	9	107TA5767
7/16" -20 UNF	15	12	13.5	107TA5768
1/2" -20 UNF	18	15	16.5	107TA5769
9/16" -18 UNF	18	12	13.5	107TA5770
9/16" -24 UNEF	18	12	13	107TA5771
5/8" -18 UNF	19.3	14.2	15	107TA5772
3/4" -16 UNF	24	18	19.5	107TA5773
7/8" -14 UNF	27	20	21.5	107TA5774
15/16" -20 UNEF	29	14	16	107TA5775
1" -14 UNS	33	14	16	107TA5776
1" -16 UN	33	14	16	107TA5777
1 1/16" -12 UN	34	23	25	107TA5778
1 1/16" -16 UN	34	14	16	107TA5779
1 3/16" -20 UN	38	14	16	107TA5780
1 1/4" -12 UNF	38	14	16	107TA5781
1 5/16" -12UN	40	24	26	107TA5782
1 7/16" -18 UNEF	44	17	19	107TA5783
1 5/8" -12 UN	50	17	19	107TA5784
1 5/8" -16 UN	50	17	19	107TA5785
1 3/4" -16 UN	53	17	19	107TA5786
1 13/16" -16 UN	53	17	19	107TA5787
1 7/8" -12 UN	55	17	19	107TA5788
1 7/8" -18 UNS	55	17	19	107TA5789
2 1/8" -12 UN	60	18	20	107TA5790
2 1/8" -16 UN	60	18	20	107TA5791
2 1/4" -12 UN	66	18	20	107TA5792
2 3/8" -16 UN	69	18	20	107TA5793
2 1/2" -12 UN	72	18	20	107TA5794
2 1/2" -16 UN	72	18	20	107TA5795

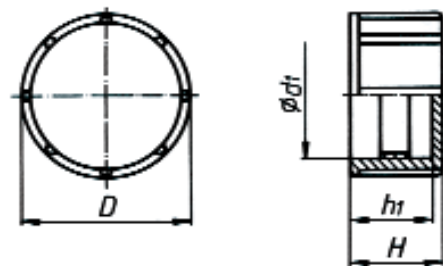



PLUG

d1	H	REF
7.2	8	107TA5803
8.4	8	107TA5804
8.6	6.5	107TA5805
9.2	6.5	107TA5806
9.4	6.5	107TA5807
10.7	7.5	107TA5808
11.7	9	107TA5809
12.3	9	107TA5810
13	9	107TA5811
13.7	10	107TA5812
14.6	7.5	107TA5813
15	10	107TA5814
15	7.5	107TA5815
15.6	10	107TA5816
16.7	7.5	107TA5817
16.5	7.5	107TA5818
16.5	7.5	107TA8689
17.1	10.5	107TA5820
18.4	10.5	107TA5821
19.3	10.5	107TA5822
21.2	9.5	107TA5823
21.7	10.5	107TA5824
19.6	10.5	107TA5825
21.5	10	107TA5826
20.7	10.5	107TA5827
22.4	12	107TA5828
23.6	12	107TA5829
24	12	107TA5830
24.6	12	107TA5831
24.5	11	107TA5832
25.5	9.5	107TA5833
26.5	12	107TA5834
29	15	107TA5835
30.5	15	107TA5836
31.8	12.5	107TA5837
33.5	15	107TA5838
34.8	18	107TA5839
35.5	18	107TA5840
36.5	18	107TA5841
38.4	12.5	107TA5842
39	18	107TA5843
40	18	107TA5844
40.7	18	107TA5845
42.3	18	107TA5846
46	21	107TA5847
48.5	15	107TA5848
51.5	21	107TA5849
55	21	107TA5850
55.8	21	107TA5851
58	21	107TA5852
66	21.5	107TA5853
71	21.5	107TA5854



PLASTIC PLUG AND QUICK COUPLING PLUGS

PLUG QUICK COUPLING

D	d1	L	REF
male plug			
1/4"	22	125	107TA5796
3/8"	22	125	107TA5797
1/2"	29	135	107TA4296
1/2"	27	135	107TA5798
female plug			
1/4"	22	125	107TA5799
3/8"	22	125	107TA5800
1/2"	29	135	107TA5801
1/2"	27	135	107TA5802

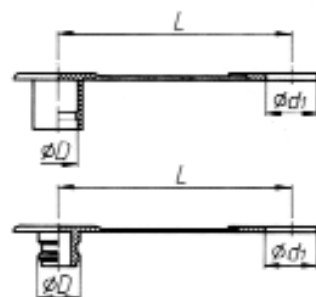

CHROME-REINFORCED AXLES FOR FORKLIFTS



- Quality: f 7 (RA 0,2)
- Thickness of the chrome layer: 25 µm
- Hardness of chrome layer: 65-70 HRC

Please indicate reference and length.

Ø (mm)	Ref per m
8	107TA5545
9,52	107TA5546
10	107TA5547
12	107TA5548
12,7	107TA5549
14	107TA5550
15	107TA5551
15,87	107TA5552
16	107TA5553
18	107TA5554
19,05	107TA5555
20	107TA5556
22	107TA5557
22,22	107TA5558
24	107TA5559
25	107TA5560
25,4	107TA5561
26	107TA5562
28	107TA5563
28,57	107TA5564
30	107TA5565
31,75	107TA5566
32	107TA5567

Ø (mm)	Ref per m
33	107TA5568
34,92	107TA5569
35	107TA5570
36	107TA5571
37	107TA5572
38	107TA5573
38,1	107TA5574
40	107TA5575
42	107TA5576
44,45	107TA5577
45	107TA5578
46	107TA5579
48	107TA5580
50	107TA5581
50,8	107TA5582
52	107TA5583
53,97	107TA5584
55	107TA5585
56	107TA5586
57,15	107TA5587
60	107TA5588
63	107TA5589
63,5	107TA5590

Ø (mm)	Ref per m
65	107TA5591
69,85	107TA5592
70	107TA5593
75	107TA5594
76,2	107TA5595
77	107TA5596
80	107TA5597
82,55	107TA5598
85	107TA5599
88,9	107TA5600
90	107TA5601
92	107TA5602
95	107TA5603
100	107TA5604
101,6	107TA5605
110	107TA5606
114,3	107TA5607
120	107TA5608
125	107TA5609
127	107TA5610
130	107TA5611
140	107TA5612

YELLOW PROTECTION NET



REF 107TA5614
1 box of 100 metres

RED PROTECTION NET



REF 107TA5613
1 box of 100 metres

CHROME

