

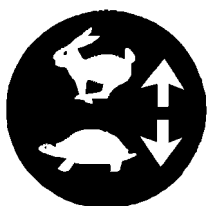

- SIGNALISATION
- SAFETY DECALS
- SAFETY SHOES
- SAFETY CLOTHES
- SAFETY MASKS
- SAFETY GLASSES
- ...

SAFETY & WAREHOUSE PRODUCTS





REF 107TA7973
(Ø 31 mm)



REF 107TA7972
(98 x 35 mm)



REF 107TA7971
(90 x 23 mm)



REF 107TA7980
(236 x 75 mm)



REF 107TA7978
(265 x 90 mm)



REF 107TA7977
(85 x 99 mm)



REF 122TA7591
(80 x 140 mm)



REF 107TA7979
(80 x 38 mm)



REF 107TA7681
transparent and adhesive
surround (32 x 15 mm)



REF 107TA7976
(104 x 50 mm)



REF 107TA7974
(110 x 110 mm)

WARNING STICKERS



Supply your goods with a warning sticker and your goods will arrive without damage!

- Increase the attention value
- Are clearly readable
- Simple to apply

500 labels/roll

REF 107TA7969 : "fragile"
6x4 - red on white

REF 107TA7967 : "arrow up"
6x4 - red on white

REF 107TA7970 : "fragile"
9x11.5 - red on white

REF 107TA7968 : "arrow up"
9x11.5 - red on white



SAFETY DECALS



REF 107TA7981
(107 x 48 mm)



REF 107TA7995
(57 x 40 mm)
red on white



REF 107TA7992
(Ø 100 mm)
REF 107TA7993
(Ø 200 mm)



REF 107TA7987
(Ø 100 mm)
REF 107TA7988
(Ø 200 mm)



REF 107TA7998
(Ø 43 mm)



REF 107TA7996
(Ø 43 mm)



REF 107TA7990
(Ø 100 mm)
REF 107TA7991
(Ø 200 mm)



REF 107TA7982
(Ø 79 mm)



REF 107TA7986 200mm



REF 107TA7985 100mm
3 pieces



REF 107TA7989
(110 x 130 mm)



REF 107TA7984
(110 x 62 mm)



REF 107TA7997
(121 x 130 mm)



REF 107TA7994
(59 x 19 mm)
black and silver



REF 107TA7979
(80 x 38 mm)



REF 107TA7983
(57 x 17 mm)

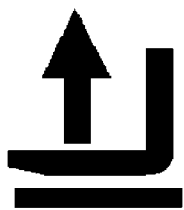

REF 107TA7679
(25 x 15 mm)
white on transparent

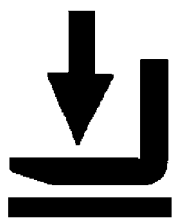

REF 107TA7680
(25 x 15 mm)
white on transparent



REF 107TA8008
(25 x 15 mm)
white on transparent



REF 107TA8007
(25 x 15 mm)
white on transparent



REF 107TA8011
(25 x 15 mm)
white on transparent



REF 107TA8009
(25 x 15 mm)
white on transparent

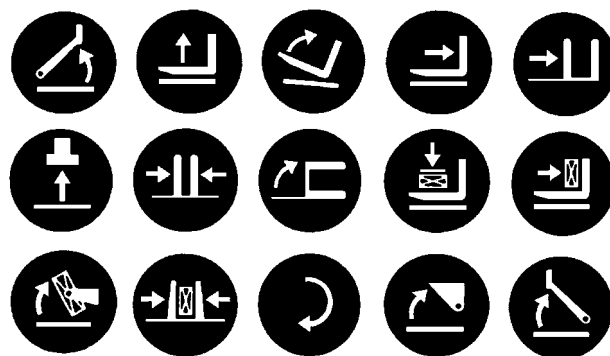

REF 107TA8006 (kit: standard decals ISO 3287) (Ø 31 mm)

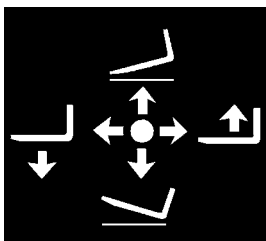

REF 107TA8010
(90 x 90 mm)
black and silver

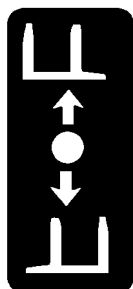

REF 107TA8001
(82 x 32 mm)
silver on black



REF 107TA8000
(89 x 39 mm)
silver on black



REF 107TA7999
(89 x 42 mm)
silver on black

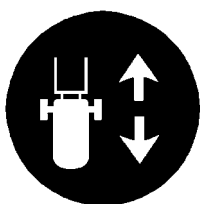

REF 107TA8005
(Ø 32 mm)
white on black



REF 107TA8004
(Ø 31 mm)
white on black



REF 107TA8003
(Ø 31 mm)
white on black



REF 107TA8002
(36 x 90 mm)
silver on black



SAFETY DECALS



REF 107TA8024
100 x 43 mm



REF 107TA8021
79 x 28 mm



REF 107TA8022
79 x 28 mm



REF 107TA8023
72 x 65 mm

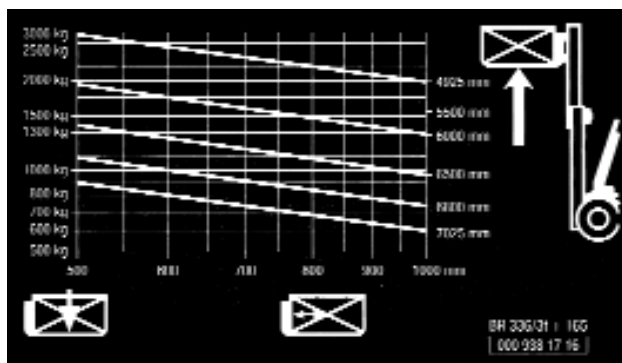

REF 107TA8012
1.6 tonnes

REF 107TA8013
2.0 tonnes

REF 107TA8014
2.5 tonnes

REF 107TA8015
3.0 tonnes



REF 107TA8020
65 x 25 mm



REF 107TA8019
40 x 40 mm

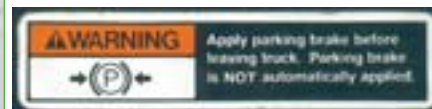

REF 107TA8017
100 x 25 mm



REF 107TA8018
106 x 55 mm



REF 107TA8016
60 x 34 mm



REF 107TA7975
(120 x 150 mm)
rating plate - metal

WARNING DECALS FOR ACCESS EQUIPMENT

WARNING DECALS FOR ACCESS EQUIPMENT



REF 107TA8031
120 x 76 mm



REF 107TA8693
101 x 76 mm



REF 107TA8029
50 x 63 mm



REF 107TA8028
75 x 55 mm



REF 107TA8027
75 x 55 mm



REF 107TA8026
50 x 63 mm



REF 107TA8702
310 x 130 mm

Please **contact** us for all make labels:

- Required:
- Name of make
 - Colour
 - Size





52 x 74 mm
REF 106TA9280

105 x 148 mm
REF 106TA9281



52 x 74 mm
REF 106TA9278

105 x 148 mm
REF 106TA9279



52 x 74 mm
REF 106TA9276

105 x 148 mm
REF 106TA9277



52 x 74 mm
REF 106TA9274

105 x 148 mm
REF 106TA9275



52 x 74 mm
REF 106TA9272

105 x 148 mm
REF 106TA9273



52 x 74 mm
REF 106TA9270

105 x 148 mm
REF 106TA9271



52 x 74 mm
REF 106TA9268

105 x 148 mm
REF 106TA9269



52 x 74 mm
REF 106TA9266

105 x 148 mm
REF 106TA9267



52 x 74 mm
REF 106TA9264

105 x 148 mm
REF 106TA9265



52 x 74 mm
REF 106TA9262

105 x 148 mm
REF 106TA9263



Note: Dutch text only!



100 x 100 mm
REF 106TA9288

148 x 148 mm
REF 106TA9289

200 x 200 mm
REF 106TA9290



7 pcs/card
REF 106TA9285

3 pcs/card
REF 106TA9286

1 pc
REF 106TA9287



7 pcs/card
REF 106TA9282

3 pcs/card
REF 106TA9283

1 pc
REF 106TA9284



rolls of 33 m
width: 50 mm
REF 106TA9300



rolls of 33 m
width: 50 mm
REF 106TA9296



rolls of 33 m
width: 50 mm
REF 106TA9292



rolls of 33 m
width: 50 mm
REF 106TA9299



rolls of 33 m
width: 50 mm
REF 106TA9295



rolls of 33 m
width: 50 mm
REF 106TA9291



rolls of 33 m
width: 50 mm
REF 106TA9298



rolls of 33 m
width: 50 mm
REF 106TA9294



rolls of 33 m
width: 50 mm
REF 106TA9297



rolls of 33 m
width: 50 mm
REF 106TA9293

*Adhesive labels on roll
33 m x 50 mm
- 600 labels/roll
- label size: 46mm(W)x64mm(L)*



ear- and head protection obligatory

REF 107TA8044 100 mm
REF 107TA8045 300 mm



head protection obligatory

REF 123TA5547 90 mm
REF 107TA8041 300 mm



hand protection obligatory

REF 107TA8036 100 mm
REF 107TA8037 300 mm



mouth protection obligatory

REF 107TA8042 100 mm
REF 107TA8043 200 mm



safety apron obligatory

REF 107TA8038 100 mm
REF 107TA8039 200 mm



face protection obligatory

REF 107TA8034 100 mm
REF 107TA8035 200 mm

KIT

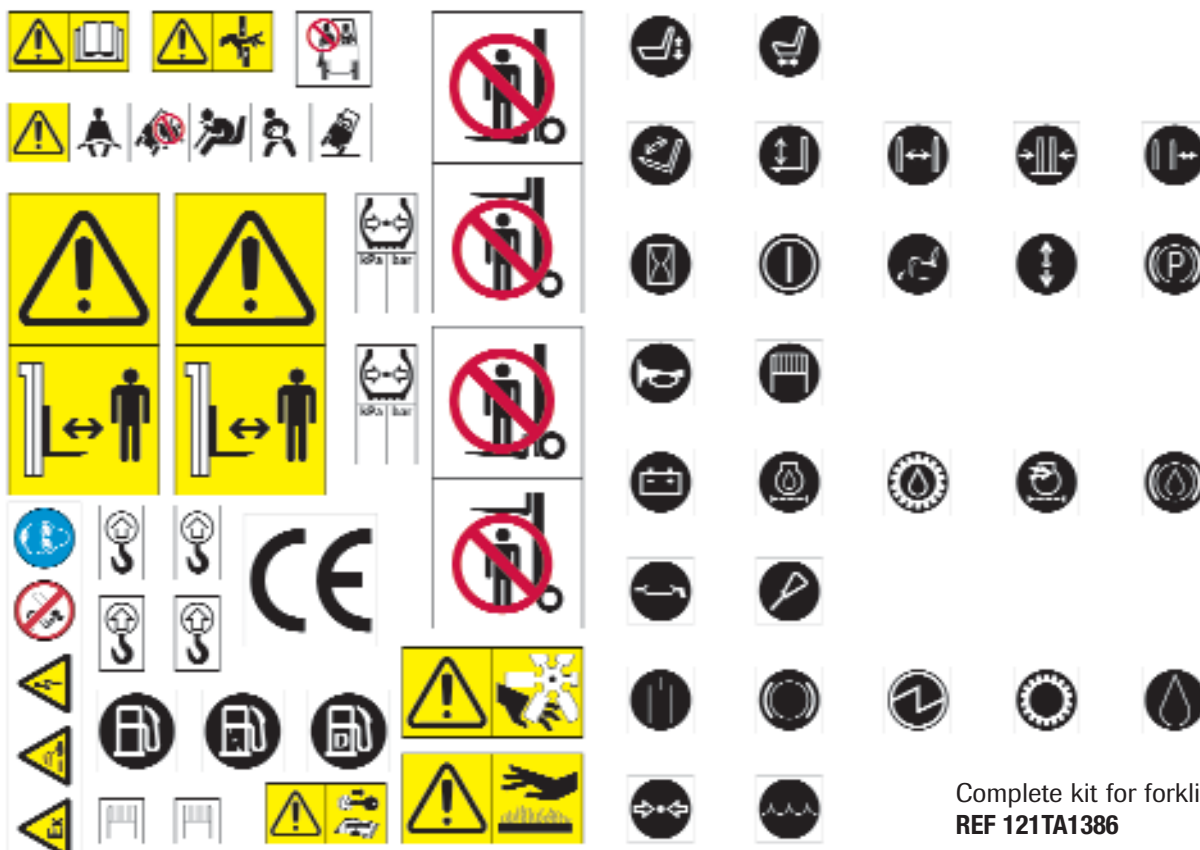

Complete kit for forklift trucks:
REF 121TA1386



SAFETY SHOES AND ACCESSORIES

SAFETY SHOE - STEEL CAPPED (SUEDE LEATHER)



ZEUS Class S1
SIZE
 38 **REF 116TA6031**
 39 **REF 116TA6032**
 40 **REF 116TA6033**
 41 **REF 116TA6034**
 42 **REF 116TA6035**
 43 **REF 116TA6036**
 44 **REF 116TA6037**
 45 **REF 116TA6038**
 46 **REF 116TA6039**
 47 **REF 116TA6040**



GEO Class S1
SIZE
 38 **REF 116TA6022**
 39 **REF 116TA6023**
 40 **REF 116TA6024**
 41 **REF 116TA6025**
 42 **REF 116TA6026**
 43 **REF 116TA6027**
 44 **REF 116TA6028**
 45 **REF 116TA6029**
 46 **REF 116TA6030**

SAFETY SHOE - STEEL CAPPED



MEXICO Class S1
SIZE (suede leather)
 38 **REF 116TA6007**
 39 **REF 116TA6008**
 40 **REF 116TA6009**
 41 **REF 107TA8061**
 42 **REF 107TA8062**
 43 **REF 107TA8063**
 44 **REF 107TA8064**
 45 **REF 107TA8065**
 46 **REF 107TA8066**

SAFETY SHOE - FIBER PLAST CAPPED



LAND Class S2
SIZE (full leather)
 38 **REF 123TA9816**
 39 **REF 123TA9817**
 40 **REF 123TA9818**
 41 **REF 123TA9819**
 42 **REF 123TA9820**
 43 **REF 123TA9821**
 44 **REF 123TA9822**
 45 **REF 123TA9823**
 46 **REF 123TA9824**



SAFETY SHOE - STEEL CAPPED



LION Class S3
SIZE (full leather)
 40 **REF 116TA6016**
 41 **REF 107TA8046**
 42 **REF 107TA8047**
 43 **REF 107TA8048**
 44 **REF 107TA8049**
 45 **REF 107TA8050**
 46 **REF 107TA8051**



DENVER Class S1
SIZE (suede leather)
 36 **REF 116TA6006**
 37 **REF 116TA6019**
 38 **REF 116TA6010**
 39 **REF 116TA6011**
 40 **REF 116TA6012**
 41 **REF 107TA8052**
 42 **REF 107TA8053**
 43 **REF 107TA8054**
 44 **REF 107TA8055**
 45 **REF 107TA8056**
 46 **REF 107TA8057**

MOSS-FILLED INNERSOLES (ANTITRANSPIRATION)



SIZE
 36 **REF 116TA5997**
 38 **REF 116TA5998**
 39 **REF 116TA5999**
 40 **REF 116TA6000**
 41 **REF 116TA6018**
 42 **REF 116TA6001**
 43 **REF 116TA6002**
 44 **REF 116TA6003**
 45 **REF 116TA6004**
 46 **REF 116TA6005**

SHOE LACES



REF 107TA8694

INVISIBLE GLOVES



REF 107TA8082 650ml. PROTECTS THE HANDS JUST LIKE GLOVES WOULD
Before each dirty job, rub some of the product into your hands. Leave on for one minute, and your skin is protected against dirt, oil, grease and lubricants

DISPOSABLE GLOVES



disposable gloves box of 100 non-steryl elastic vinyl gloves

M : **REF 107TA8079**
L : **REF 107TA8080**
XL : **REF 107TA8081**

GLOVES



REF 107TA8083
working gloves

WINTER GLOVES



REF 107TA8084
winter gloves

ALLROUND GLOVES



REF 116TA5996
Neptune T10
Leather/fabric

ACID-RESISTANT GLOVES



rubber acid-resistant gloves

size:
8 : **REF 106TA9014**
9 : **REF 106TA9015**
10 : **REF 106TA9016**
11 : **REF 106TA9017**

HEAT-RESISTANT GLOVES



REF 107TA1987
heat-resistant glove
Resistant up to 350°C (15sec.)

HEAT-RESISTANT GLOVES



REF 107TA1988
heat-resistant glove
Resistant up to 600°C

WELDING APRON



REF 107TA8085
110 cm x 80 cm

FOLDAWAY WELDING GOGGLES



REF 107TA8075
foldaway welding goggles

SAFETY GLASSES



REF 107TA8077
very light - scratch free - dim free

SAFETY GLASSES



REF 106TA9013
Acid-resistant safety glasses

RAINWEAR



REF 107TA8086
rainsuit
(jacket & pants)
only 1 size: XL

DISPOSABLE OVERALLS



disposable sprayer overalls
M: **REF 107TA7420**
L: **REF 107TA7421**
XL: **REF 107TA7422**
XXL: **REF 107TA7423**

ACID-RESISTANT APRON



REF 106TA9018
acid-resistant apron

THERMIC FACE MASK

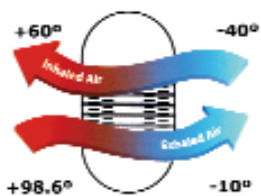

REF 124TA2790
ideal for refrigerated areas to -40°C
Regulates body temperature
Warms face, ears and neck
module replaceable if damaged or lost

DISPOSABLE MASKS



REF 107TA8058
Box of 20 masks

SAFETY JACKET



YELLOW

UNI-SIZE: 123TA5548

ORANGE

UNI-SIZE: 123TA5549

CE CERTIFIED, EN-471

FLEXOTHANE JACKET



M: **REF 116TA6043**
L: **REF 116TA6042**
XL: **REF 116TA6041**
XXL: **REF 116TA6044**

EAR PROTECTORS

REF 107TA8087
ear protectors, multipositional



EARPLUGS



REF 107TA8088
box of 200 pairs of earplugs

SAFETY HELMET

- YELLOW** REF 107TA8105
- GREEN** REF 107TA8106
- ORANGE** REF 107TA8107
- RED** REF 107TA8108
- WHITE** REF 107TA8109

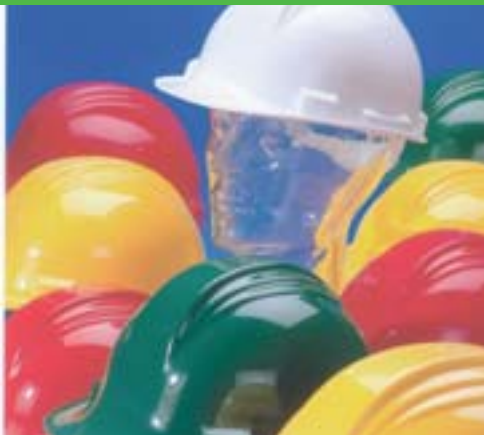

FACESHIELD

REF 107TA8076
face and head-protective shield



BACKSUPPORT

- REF 107TA8101**
medium
- REF 107TA8102**
large
- REF 107TA8103**
extra large

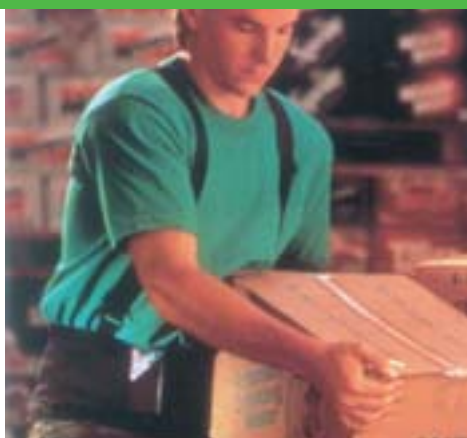

KNEE PROTECTION



REF 107TA8104
knee protector with joint, extremely strong, non-marking grip strip and isolation pad

HIPMAT



REF 107TA8100 (42 x 99 cm - thickness 3 cm)

KNEEMAT



REF 107TA8099 (30 x 35 cm - thickness 3 cm)

MAINTENANCE TROLLEY



REF 107TA8098
For maintenance and repair under the chassis of your vehicles...
Safe working position
Length x width: 1030 x 445 mm
Height of head rest: 150 mm

MAINTENANCE TROLLEY



REF 107TA8097

FIRE EXTINGUISHERS

Powder extinguishers supplied with wall mounting bracket!



1 Kg



2 Kg



3 Kg

Contents	REF
1 kg	107TA8110
2 kg	107TA8111
3 kg	107TA8112

In conformity with BENOR / CE / EN3 regulations
Instructions in dutch & french only!!

SIGNALS & FIRE EXTINGUISHERS

FIRE BLANKET



1800 x 1800 mm: **REF 107TA8114**
1200 x 1200 mm: **REF 107TA8115**
900 x 900 mm: **REF 107TA8116**

SAFETY DECAL



200 x 200 mm
REF 107TA8113

EMERGENCY SHOWERS



REF 106TA9019
emergency shower complete
with eyewash bath - FIXED unit



PLASTIC BOARDS



REF 106TA9010
emergency shower - 200 x 200 mm
REF 106TA9011
eyeshower - 200 x 200 mm



REF 106TA9012
PORTABLE emergency shower

EYEWASHING KIT



REF 106TA9005
eyewashing bottle kit
complete with sterile bandages
etc. ...

FIRST-AID KIT



REF 106TA9004
emergency first-aid kit
complete with tongs, plasters and
eyewash etc. ...

EYEWASHING BOTTLES



support - **REF 106TA9008**
400 ml - **REF 106TA9006**
800 ml - **REF 106TA9007**

FIRST-AID KIT



REF 106TA8997
first-aid kit





ADHESIVE ANTISLIP

ANTISLIP



width	length	REF
0,178 m	0,204 m	107TA5236
0,305 m	1 m	107TA5237
0,61 m	1 m	107TA5238
0,019 m	18,3 m	107TA5239
0,1 m	18,3 m	107TA5240
0,15 m	18,3 m	107TA5241
0,20 m	18,3 m	107TA5242
0,30 m	18,3 m	107TA5243
0,61 m	18,3 m	107TA5244



0,05 m	18,3 m	107TA8123
0,025 m	18,3 m	107TA8124
0,10 m	18,3 m	107TA8125

fluorescent antislip tape

0,025 m	18,3 m	107TA8126
0,05 m	18,3 m	107TA8127
0,1 m	18,3 m	107TA8128



prevents slipping of objects and materials - the product has excellent non-slip characteristics to protect against damage to slick surfaces - cuts to size with scissors

0,91 m	18,3 m	107TA8130
1,22 m	18,3 m	107TA8131



Antislip spray
400 ml:

REF 107TA8122

107TA8122

SAFETY TAPE

STANDARD



Red/white or yellow/black chequered polyethylene foil. Width approx. 80mm. L: 500m

REF 107TA8138

Red/white

REF 107TA8139

Yellow/black

NYLON REINFORCED



Polyethylene foil consisting of 2 layers of red/white chequered tape, with 2 nylon wires welded into them. Extremely strong. Width 80mm. Comes delivered on a plastic reel.

REF 116TA5642

Red/white

SUPER



Printed red/white. Thickness < 70µ, width 80mm, comes delivered on a handy unwinding coil.

REF 116TA5643

Red/white

FENCE POLE



Increase security thanks to rounded link! Safety tape, warning tape, plastic chain and construction/warning lights can easily be fixed to this pole.

REF 116TA5641

Length 1300mm

ADHESIVE SIGNAL TAPE



WIDTH	COLOUR	REF
38 mm	YELLOW/BLACK	107TA8148
50 mm	YELLOW/BLACK	107TA8149
75 mm	YELLOW/BLACK	107TA8150
38 mm	RED/WHITE	107TA8151
50 mm	RED/WHITE	107TA8152
75 mm	RED/WHITE	107TA8153

NON-ADHESIVE SIGNAL TAPE



REF 107TA8139

Standard roll of signal tape 500 m non-adhesive



REF 107TA8138

Standard roll of signal tape 500 m non-adhesive



REF 107TA8137

Protection box (against damp and damage) for easy use

RETROREFLECTIVE ADHESIVE BANDS

Length	width 165 mm		width 250 mm	
	Right	Left	Right	Left
10 m	REF 107TA8143	REF 107TA8140	REF 107TA8141	REF 107TA8142
50 m	REF 107TA8147	REF 107TA8144	REF 107TA8145	REF 107TA8146



COLLAPSIBLE POST ON SQUARE CUP



REF 107TA8163
Red & white

REF 124TA1598
White

REF 124TA1599
Yellow & black

Height: 90 cm
Tube ø: 50 mm

SAFETY BAR



REF 107TA8165
Length: 1 m
Tube ø: 40 mm
Only red and white

REF 107TA8164
Length: 2 m
Tube ø: 40 mm
Only red and white

SIGNALLING CHAINS (BAG OF 25 M)



Diam.	REF (red & white)	Diam.	REF (black & yellow)
6 mm	107TA8169	6 mm	107TA8166
8 mm	107TA8170	8 mm	107TA8167
10 mm	107TA8171	10 mm	107TA8168

ADHESIVE HANGER



REF 107TA8162
dimensions: 90 x 60 x 59 mm

LUMINESCENT TAPE FOR EXTERNAL USE



55 mm width, 1m length

White: **REF 107TA8154**
Yellow: **REF 107TA8155**
Red: **REF 107TA8156**

LUMINESCENT TAPE FOR INTERNAL USE



width (mm)	length (m)	
15	10	REF 107TA8158
20	1	REF 115TA6904
25	25	REF 107TA8159
50	25	REF 107TA8160
100	25	REF 107TA8161

TRAFFIC MIRROR



REF 107TA8179

diameter: 800 mm
Acryl - Red/white - Inner and outer
Supplied with attachment in stainless, galvanised steel - Beam or wall

TRAFFIC MIRROR



REF 107TA8178

dimensions: 800 x 600 mm
Acryl - Red/white - Inner and outer
Supplied with attachment in stainless, galvanised steel - Beam or wall

TRAFFIC MIRROR

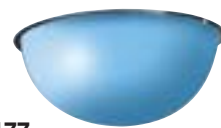

REF 107TA8177

diameter: 800 mm
Acryl (70 x stronger, more shock-resistant than glass)
360° - For use inside

LIGHTWEIGHT AND ROBUST BARRIERS



- caution - out of service
- caution - wet floor
- temporarily closed
- danger - keep out
- cleaning in progress
- caution - work area

FOR ALL PUBLIC AREAS

REF 107TA8174 PER PAIR

size: 1030 x 780 x 26 mm • weight: 2,5 kg
Choose your sign from the 6 self-adhesive signs which are supplied free with every unit.

RACKING PROTECTION



REF 107TA8173

Height 560 mm
Includes 4 floor fixings. Made in a U-section protecting column on three sides. Finished in machine green RAL 6011 and with black-yellow stripes (DIN 4844)



REF 107TA8172

Height 400 mm
Includes 4 floor fixings
Made of powdercoated epoxy-polyester, colour yellow, RAL 1003 and with black-yellow stripes (DIN 4844)

ROLL PROTECTION



REF 107TA8176

height: 1000 mm - weight: 10 kg - per 2

FLAG

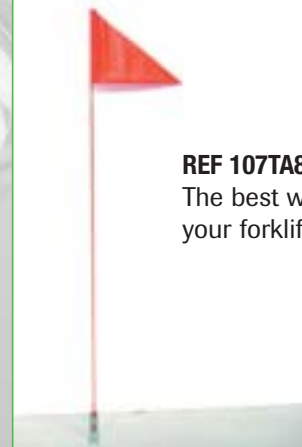

REF 107TA8181

The best way to find your forklift

SPEED BUMPS



REF 107TA8182

Length: 2 m
Width: 25 cm

WELDING CURTAIN



REF 107TA8183

2 x 2 m

REF 107TA8184

2 x 3 m



WARNING LAMPS

KEY

A: REF 107TA8119
2 batteries needed

B: REF 107TA8120
with security clamp
2 batteries needed

C: REF 107TA8121
Monolight, one battery
with security clamp

delivered without battery



REF 107TA8118



BATTERY

REF 107TA8117



WAREHOUSE SAFETY

ECONOMIC FLASH XENON STROBE LIGHT

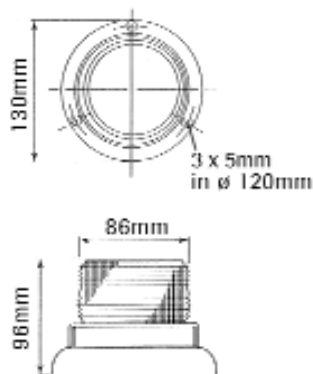

Strobe light:	12/110 VDC	240 VAC
Amber	REF 105TA4867	REF 106TA9118
Blue	REF 106TA9123	REF 106TA9119
Clear	REF 106TA9124	REF 106TA9120
Green	REF 105TA4868	REF 106TA9121
Red	REF 106TA9125	REF 106TA9122

ROTATING LIGHT 230 VOLT



For safety purposes inside and outside workshops, warehouses, ...

REF	Bulbtype	Bulb partnumber	Mounting-way	Welding type	Screw-in type	Cap only (amber)
107TA8610	standard (230V)	REF 107TA8613	pipe-mounting	REF 106TA9131	REF 106TA9132	REF 107TA8615
107TA8611	halogen	REF 107TA8614	pipe-mounting	REF 106TA9131	REF 106TA9132	REF 107TA8615
107TA8180	standard (230V)	REF 107TA8613	standard			REF 107TA8615
107TA8612	halogen	REF 107TA8614	standard			REF 107TA8615

ROADSIDE WARNINGS



compulsory warning triangle for all road vehicles - size 40 x 35 cm

REF 107TA8059 (to hang up)
REF 107TA8060 (triangle support stand)

BRIGHT STAR TORCH



REF 107TA8136

TRAFFIC CONE



30 cm - REF 107TA8133
50 cm - REF 107TA8134
70 cm - REF 107TA8135

LED TRIANGLE

on/off button
water resistant
magnet / stand for use on road
attachable to traffic cone & warning triangle
height: 170mm
width: 170mm
depth: 37mm

RED	REF 124TA2789
ORANGE	REF 124TA2792
WHITE	REF 124TA2793
BLUE	REF 124TA2794
GREEN	REF 124TA2795



REFLECTORS FOR FORKLIFTS

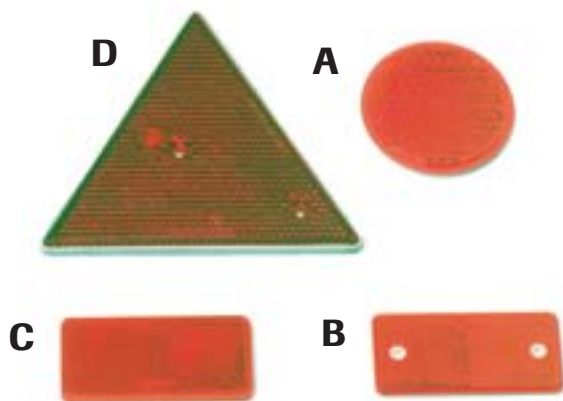

A	REF 106TA1321 adhesive	diameter 80 mm
	REF 107TA8074 adhesive	diameter 60 mm
B	REF 106TA1322	44 x 94 mm
C	REF 106TA1323 adhesive	44 x 94 mm
D	REF 106TA1324	height: 140 mm

This is only a selection of what we can offer. Call our sales department for more details.

PROTECTA PROFESSIONAL HEIGHT SAFETY KIT



A) Pro 101 harness

1 Dorsal attachment D-ring
adjustment: thigh and shoulder straps



EN361



B) Snaphook 'Manucroche' AJ302

Stainless steel
Plastic handles
Strength > 24 kN
With opening of 110 mm



EN 362



D) Duffel bag AK043

ø 300 x 500 mm



EN 355

C) Energy absorber fall arrest lanyard AE522/1

Energy absorber fall arrest with wrench webbing and 1,5 m lanyard
With screw carabiner AJ501 17 mm opening
Braided rope ø 10,5 mm

REF 116TA5995

Protecta professional height safety kit

Minimum working height 6M!

Included:

- A) full body harness: one-point attachment
 - B) snaphook 'Manucroche' self-locking
 - C) energy absorber fall arrest lanyard
 - D) storage bag
- manual with instructions



PROTECTA PROFESSIONAL HEIGHT SAFETY KIT



We have also a large programme of obsolete/hard-to-find parts. We can sell these parts either repaired, service exchange or outright sales ! Contact your sales person for more information.



Rebuilt hydraulic components



Rebuilt converters



Rebuilt orbitrols

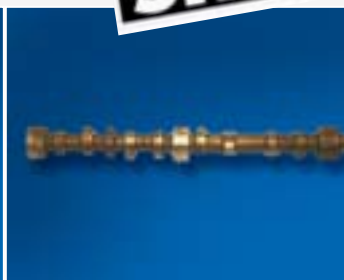

Rebuilt engine parts



Steering parts



Rebuilt pumps



Rebuilt engine hoods



Rebuilt transmissions



Rebuilt radiators



Rebuilt hubs



gears



Rebuilt body parts



Rebuilt steering units



Rebuilt injection pumps



Rebuilt steering parts



Rebuilt reducers

! 6 month warranty on all rebuilt/second hand parts

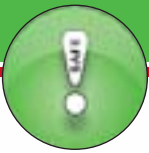

ONE STOP SHOP



Rebuilt engine parts



Rebuilt rear axles



Rebuilt differentials



Hubs



Rebuilt transmissions



Rebuilt transmissions



Tanks



gears



Rebuilt drive axles



Rebuilt overhead guard



Rebuilt drive axles



Rebuilt gearboxes



Rebuilt steering cylinders



Rebuilt tilt cylinders



View of our service exchange department



6 month warranty on all rebuilt/second hand parts

RECONDITIONED ENGINE PARTS



TOYOTA
NISSAN
MITSUBISHI
KOMATSU
ISUZU
MAZDA

CONTINENTAL
PERKINS
WAUKESHA
FORD
GM
CATERPILLAR
CUMMINS
DETROIT
CHRYSLER

DEUTZ
VOLVO
MERCEDES
VOLKSWAGEN
FIAT-OM
PEUGEOT
RENAULT

Reconditioned engine parts available !! Call us.

 **6 month warranty on all rebuilt/second hand parts**

 SERVICE EXCHANGE
REBUILT AVAILABLE

