

- ✓ *Simple to use*
- ✓ *A compact stacker, for any purpose, to fit every budget*

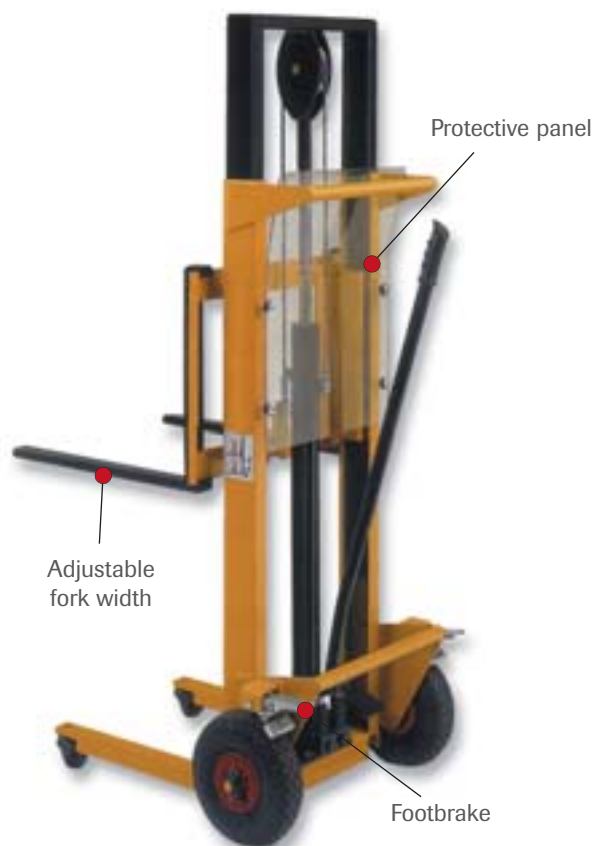

REF 107TA8245

Diablo manual stacker

REF 111TA4131

Liftruck with winch

- ✓ Durable galvanized steel
- ✓ Ergonomic universal tool

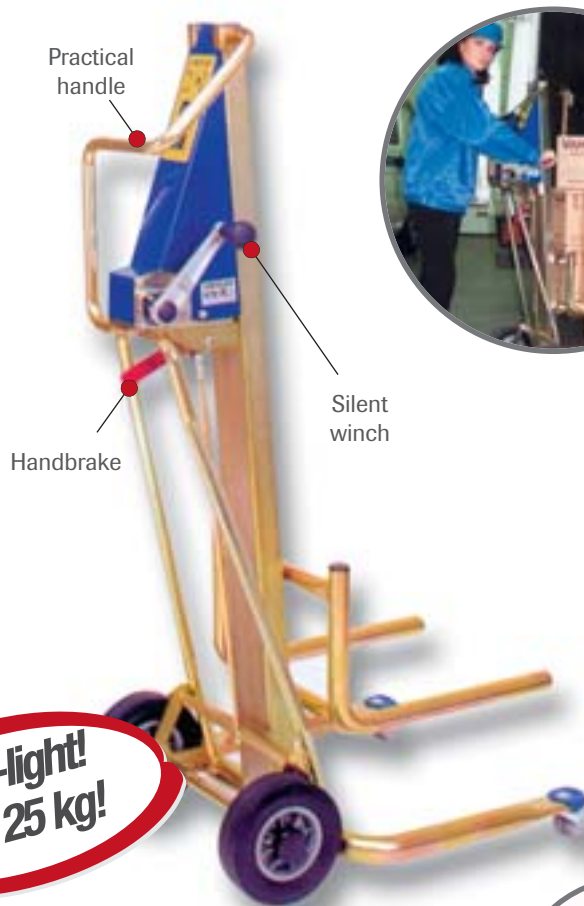

**Ultra-light!
Just 25 kg!**

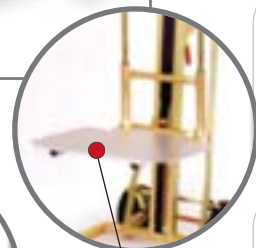

Option: Stainless steel folding platform



Option: Raised load bracket

REF	107TA8245	111TA4131
LIFTING CAPACITY (KG)	250	120 kg at 300 mm load centre of gravity 170 kg at 210 mm load centre of gravity
LIFT HEIGHT (MM)	1600	1100
STACKER HEIGHT (MM)	2075	1375
WIDTH (MM)	680	590
LIFTING SPEED	20 mm / arm stroke	70 mm / arm stroke
FRONT WHEELS (MM)	50	50
REAR WHEELS (MM)	260 pneumatic tyres	200 solid rubber
FORK LENGTH (MM)	500	400
FORK WIDTH (MM)	530	/
WEIGHT (KG)	90	25

REF 119TA8880

Handylift



This manual stacker can also be used as a hand trolley!



REF 119TA8881

Handylift

- ✓ **Manual stackers for light loads**
e.g. heaters, air conditioning units, sanitary etc.
- ✓ **Easy to transport**
in delivery van
- ✓ **Maintenance-free**
- ✓ **Flexible**

REF 107TA8244

Winchmaster



REF	119TA8880	119TA8881	107TA8244
LIFT HEIGHT (MM)	1066	1066	1500
CAPACITY (KG)	300	300	150
FORK LENGTH (MM)	406	406	510
FORK WIDTH OUTSIDE (MM)	300	490	Max. 610 (adjustable)
FRONT WHEELS (MM)	80	80	80
REAR WHEELS (MM)	200	100	120 (with brake)
WEIGHT (KG)	50	52.3	83
WEIGHT (KG)	winch	winch	winch
OVERALL HEIGHT (MM)	1473	1260	1925
OVERALL LENGTH/WIDTH	635/610	770/490	975/610



EUROLIFTER stackers for light loads of 250 to 500 kg!

Eurolifter

- ✓ *Eurolifter stackers for light loads of 250 to 500 kg!*
- ✓ *Nylon wheels*
- ✓ *1 swivel castor with footbrake*



REF 108TA8481 AND 108TA8482
Eurolifter manual stacker

Also available with electric lift!



REF 108TA8476 TO 108TA8479
Eurolifter stacker (duplex mast)

- ✓ Available with 70 Ah battery and 12 V charger
- ✓ Developed for a long service life with a minimum of maintenance

REF	Manual/Elect. lift	Lift height (mm)	Lifting capacity (kg)	Fork length (mm)	Width over forks	Lifting speed	Wheels front	Wheels rear	Weight (kg)
108TA8476	M	1830	250	500	635	33mm/stroke	80	125	106
108TA8477	M	2450	250	500	635	40mm/stroke	80	125	136
108TA8478	E	1830	250	500	635	6sec/metre	80	125	146
108TA8479	E	2450	250	500	635	6sec/metre	80	125	200
108TA8481	M	1500	500	1140	528	17mm/stroke	80	150	159
108TA8482	M	2100	500	1140	528	17mm/stroke	80	150	199

Eurolifter

- ✓ *Ideal for loading and unloading delivery vans!*
- ✓ *Your money's worth!*

For lifting heavy loads!

REF 116TA5894

Eurolifter manual stacker for heavy loads

- ✓ With Quicklift pump
- ✓ 2-year warranty on hydraulic pump
- ✓ 1 swivel castor with footbrake
- ✓ Dual nylon fork wheels



Foot pump

Nylon swivel castor with foot protection

REF

116TA5894

REF	116TA5894
LIFTING CAPACITY (KG)	1000
LIFT HEIGHT MIN. (MM)	90
LIFT HEIGHT MAX. (MM)	1600
OVERALL HEIGHT (MM)	2020
FORK LENGTH (MM)	1140
WIDTH OVER FORKS (MM)	560
OVERALL WIDTH (MM)	700
OVERALL LENGTH (MM)	1560
Ø STEERING WHEELS (MM)	150 - Nylon
Ø FORK WHEELS (MM)	80 - Tandem nylon
TURNING CIRCLE (MM)	1400
OWN WEIGHT (KG)	230

€urolifter

- ✓ *Ideal for loading and unloading delivery vans!*
- ✓ *Your money's worth!*

With electric lift!



Nylon swivel castor with foot protection

REF 121TA1375

Eurolifter semi-electric stacker for heavy loads

- ✓ With integrated charger
- ✓ Dual nylon fork wheels

REF	121TA1375
LIFTING CAPACITY (KG)	1000
LIFT HEIGHT MIN. (MM)	90
LIFT HEIGHT MAX. (MM)	1600
OVERALL HEIGHT (MM)	2020
FORK LENGTH (MM)	1140
WIDTH OVER FORKS (MM)	560
OVERALL WIDTH (MM)	700
OVERALL LENGTH (MM)	1560
Ø STEERING WHEELS (MM)	150 - Nylon
Ø FORK WHEELS (MM)	80 - Tandem nylon
TURNING CIRCLE (MM)	1400
OWN WEIGHT (KG)	315



**Robust mast rollers
allow
the forks to lift and
lower smoothly**



REF 107TA8765

SERIES MX
Pramac manual stacker
for heavy loads



**1 footbrake on
right swivel castor**



Ideal for less intensive use!!

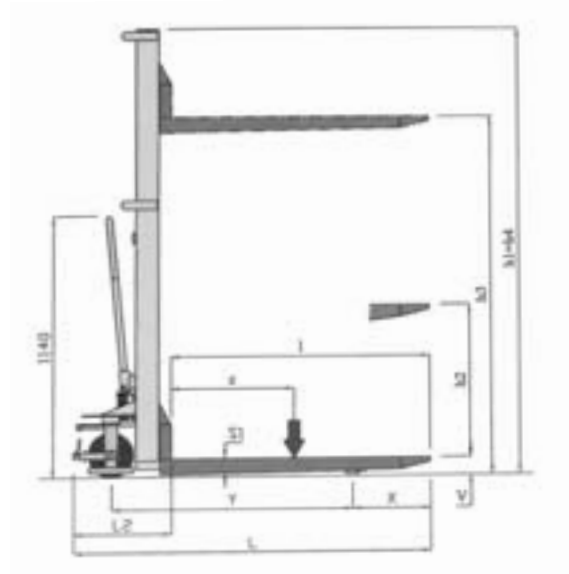
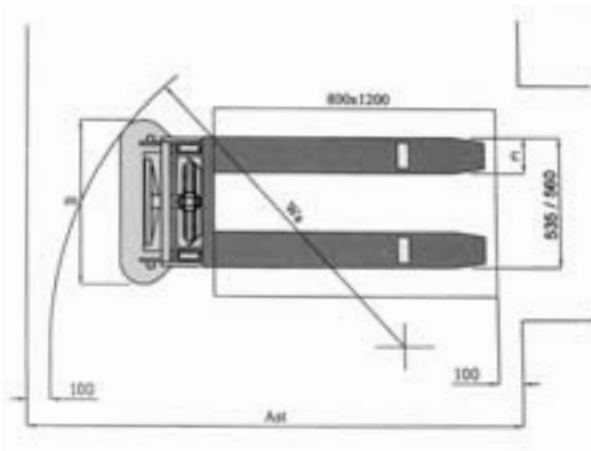

REF	107TA8763	107TA8764	107TA8765
MODEL	MX410	MX416	MX816
LIFTING CAPACITY (KG)	400	400	800
MAX. LIFT HEIGHT (MM)	1000	1600	1600
FREE HEIGHT MAX. (MM)	920	1520	1515
FORK LENGTH (MM)	1150	1150	1150
FORK WIDTH / THICKNESS (MM)	130 / 70	130 / 70	157 / 70
OVERALL LENGTH	1530	1530	1590
LENGTH OF BODY	380	380	440
WIDTH(MM)	585	585	700
HEADROOM (MM)	1360	2010	2010
MAX. HEIGHT (MM)	1360	2010	2010
TURNING CIRCLE (MM)	1300	1300	1730
AISLE WIDTH (MM)	1880	1880	2310
WEIGHT (KG)	126	136	235
WHEELS STEERING/FORK WHEELS	2 / 2	2 / 2	2 / 2
TYRES STEERING/FORK WHEELS	Nylon	Nylon	Nylon
BRAKE	Mechanical	Mechanical	Mechanical



Powerful hydraulic pump

REF 119TA8561

Manual stacker
For heavy loads up to 1000 kg!
 Standard fork length 1150mm

- ✓ *Compact!*
- ✓ *Versatile!*
- ✓ *Simple to use!*
- ✓ *Short rear construction!*
- ✓ *Low rolling resistance!*
- ✓ *Custom manufacturing possible!*

For loads of 250 to 1000 kg!



Powerful hydraulic pump

REF 111TA4133 TO 111TA4135

Manual stacker
 With adjustable forks

REF	111TA4134	111TA4135	111TA4133	119TA8561
Lifting capacity (kg)	250	500	1000	1000
Load centre (mm)	400	400	400	600
Lift height (mm)	1600	1600	1600	1600
Free lift (mm)	1600	1600	1600	1450
Stacker height (mm)	2000	2000	2000	1990
Overall width (mm)	800	800	800	755
Fork length (mm)	800	800	800	1150
Width across forks (mm)	adjustable 200-800	adjustable 200-800	adjustable 200-800	560
Fork width (mm)	100	100	100	160
Turning circle (mm)	990	1125	1125	1320
Aisle width with europallet (mm)	1500	1600	1600	1600
Hydraulic pump	single operation	dual operation	dual operation	single operation
Number of pump movements	20/20	80/18	80/18	25
Lift per pump movement (mm)	90	90	90	90
Own weight (kg)	92	144	190	264
Steering wheels w x diam. (mm)	polyurethane 40 x 120	polyurethane 50 x 150	polyurethane 50 x 150	polyurethane 50 x 200
Fork rollers w x diam. (mm)	polyurethane 70 x 80	polyurethane 30 x 80	polyurethane 70 x 80	polyurethane 70 x 80

- ✓ *For lifting heavy loads!*
- ✓ *Ideal for loading and unloading delivery vans!*



REF 111TA4132

Manual stacker up to 800 mm



REF 119TA8562

Stacker with lateral tilt

Lateral tilt
20° to the left
20° to the right!

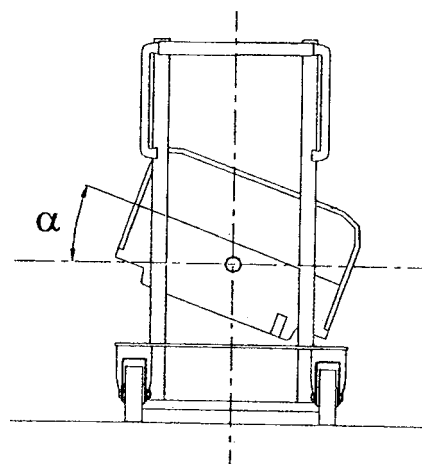

REF	111TA4132	119TA8562
LIFTING CAPACITY (KG)	1000	1000 (forks horizontal) 400 (forks tilted)
LIFTING HEIGHT (MM)	800	800
FORK LENGTH (MM)	1150	900
FORK WIDTH OUTSIDE (MM)	Adjustable 200 - 800	445
FRONT WHEELS (MM)	70x80 (polyurethane)	80 (polyurethane)
REAR WHEELS (MM)	50x150 (polyurethane)	200 (polyurethane)
LIFTING SPEED MM/STROKE	33	20/90 (with/without load)
WEIGHT (KG)	141	160



- ✓ *Starter battery and built-in charger included!*
- ✓ *Versatile use*
- ✓ *Polyurethane wheels for comfortable driving*
- ✓ *1-year of warranty on parts!*

**Electric lift,
manual
propulsion!**



With mechanical brake

REF 107TA8769

SERIES TX
Semi-electric stacker
Electric lift, manual propulsion

- ✓ Series TX 10: lifting capacity 1000 kg
- ✓ Series TX 12: lifting capacity 1200 kg



Mechanical brake



**Ignition key =
emergency brake**



**Integrated
battery charger
with indicator**

Battery and charger included!

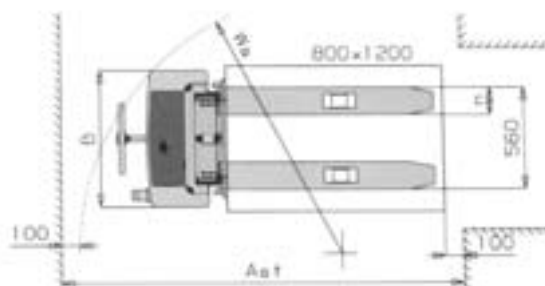
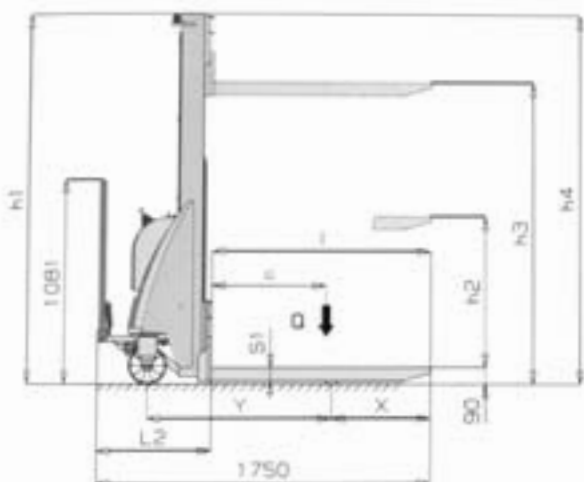

REF		107TA8766	107TA8767	107TA8768	107TA8769	107TA8770	107TA8771
Features	Q	TX 10/09	TX 10/16	TX 10/20	TX 12/25	TX 12/29	TX 12/35
Lifting capacity (kg)	C	1000	1000	1000	1200	1200	1200
Centre of gravity (mm)		600	600	600	600	600	600
Lift height (mm)	h3	900	1600	2000	2500	2900	3500
Free lift (mm)	h2	810	1510	1910	-	-	80
Fork length (mm)	l	1150	1150	1150	1150	1150	1150
Fork width x thickness (mm)	nXS1	150x70	150x70	150x70	150x70	150x70	150x70
Overall length (mm)	L	1750	1750	1750	1850	1850	1850
Length of steering mechanism (mm)	L2	600	600	600	700	700	700
Width (mm)	B	750	750	750	850	850	850
Headroom (mm)	h1	1300	1970	2370	1780	1980	2250
Max. height (mm)	h4	1300	1970	2370	2985	3385	3915
Turning circle (mm)	Wa	1440	1440	1440	1760	1760	1760
Aisle width 800 x 1200 (mm)	Ast	2210	2210	2210	2375	2375	2375
Lowering with/without load (m/s)		0.09/0.12	0.09/0.12	0.09/0.12	0.07/0.10	0.07/0.10	0.07/0.10
Lifting with/without load (m/s)		0.4/0.1	0.4/0.1	0.4/0.1	0.4/0.1	0.4/0.1	0.4/0.1
Steering/fork wheels (No)		2/2	2/2	2/2	2/2	2/2	2/2
Steering/fork wheels*		G/N	G/N	G/N	P/N	P/N	P/N
Dim. steering wheels (mmØ)		200x50	200x50	200x50	200x50	200x50	200x50
Dim. fork wheels (mmØ)		82x70	82x70	82x70	82x70	82x70	82x70
Dist. betw. steering and fork wheels (mm)	Y	965	965	965	1155	1155	1155
Dist. betw. fork wheels and fork ends (mm)	X	520	520	520	365	365	365
Lift motor drive (kW)		1.6	1.6	1.6	2.2	2.2	2.2
Voltage/power (V/Ah)		12/70	12/70	12/70	24/70	24/70	24/70
Battery weight (kg)		18	18	18	36	36	36
Battery charger (V-A)		12-15	12-15	12-15	24-13	24-13	24/13
Weight with battery charger (Kg)		290	305	315	424	440	485

* P = polyurethane - G = rubber - N = nylon



Ergonomic handle



Integrated battery charger



Plus version with traction battery for longer battery life



REF 111TA4228

SERIES GX
Electric stacker
Electric lift and propulsion

- ✓ Choice between starter or traction battery for light-duty or more intensive use
- ✓ With built-in battery and charger
- ✓ Electrically actuated brake
- ✓ 1-year warranty on parts!
- ✓ Option: maintenance-free gel battery for use in agro-chemical environment

Electric lift and propulsion!



REF		108TA8949	108TA8950	108TA8951	108TA8952	108TA8953
Features		GX 10/09	GX 10/16	GX 10/20	GX 12/25	GX 12/29
Lifting capacity (kg)	Q	1000	1000	1000	1200	1200
Load centre of gravity (mm)	C	600	600	600	600	600
Lift height (mm)	h3	900	1600	2000	2500	2900
Free lift (mm)	h2	810	1510	1910	/	/
Fork length (mm)	l	1150	1150	1150	1150	1150
Fork width x thickness (mm)	nXS1	150x70	150x70	150x70	150x70	150x70
Overall length (mm)	L	1825	1825	1825	1825	1825
Length of steering mechanism (mm)	L2	675	675	675	675	675
Overall width (mm)	B	850	850	850	850	850
Headroom (mm)	h1	1300	1970	2370	1780	1980
Max. height (mm)	h4	1300	1970	2370	2985	3385
Turning circle (mm)	Wa	1460	1460	1460	1460	1460
Aisle width 800 x 1200 mm (mm)	Ast	2075	2075	2075	2075	2075
Speed with/without load (km/h)		4.0/5.0	4.0/5.0	4.0/5.0	4.0/5.0	4.0/5.0
Lifting with/without load (m/s)		0.09/0.12	0.09/0.12	0.09/0.12	0.07/0.10	0.07/0.10
Lowering with/without load (m/s)		0.4/0.1	0.4/0.1	0.4/0.1	0.4/0.1	0.4/0.1
Max. gradient with/without load (%)		5/10	5/10	5/10	5/10	5/10
Own weight with battery (kg)		369	390	410	490	505
Steering/fork wheels (No)		2+1 M/2	2+1 M/2	2+1 M/2	2+1 M/2	2+1 M/2
Steering/fork wheels*		P+G/P	P+G/P	P+G/P	P+G/P	P+G/P
Dimensions of drive wheels (mmØ)		240x60	240x60	240x60	250x76	250x76
Dimensions of support wheels (mmØ)		150x40	150x40	150x40	150x40	150x40
Dimensions of fork wheels (mmØ)		82x70	82x70	82x70	82x70	82x70
Dist. betw. steering and fork wheels (mm)	Y	1190	1190	1190	1190	1190
Dist. betw. fork wheels and fork ends (mm)	X	365	365	365	365	365
Traction motor (kW)		0.5	0.5	0.5	0.7	0.7
Lift motor (kW)		2.2	2.2	2.2	2.2	2.2
Traction (T)/starter battery (S)		S	S	S	S	S
Voltage (V)		24	24	24	24	24
Power (Ah)		70	70	70	92	92
Duration of charge (h)		3	3	3	3	3
Battery weight (kg)		36	36	36	44	44
Battery charger (V-A)		24-13	24-13	24-13	24-20	24-20

* P = polyurethane - G = rubber - N = nylon

SERIES GX

Electric stacker
Electric lift and propulsion

Battery and charger included!

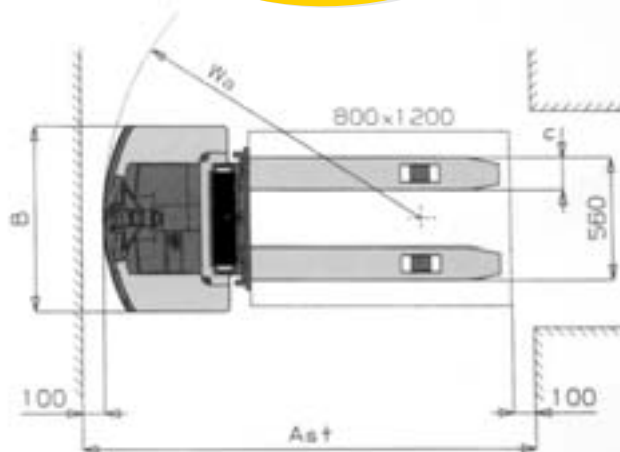
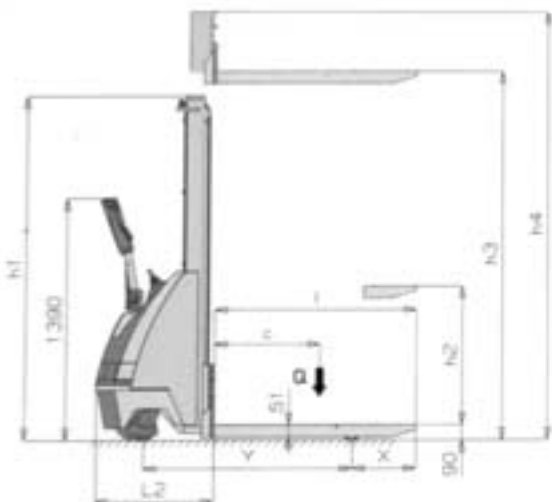

STACKERS ELECTRIC

REF		108TA8954	111TA4228	111TA4229	111TA4230
Features		GX 12/35	GX 12/25	GX 12/29	GX 12/35
Lifting capacity (kg)	Q	1200	1200	1200	1200
Load centre of gravity (mm)	C	600	600	600	600
Lift height (mm)	h3	3500	2500	2900	3500
Free lift (mm)	h2	80	/	/	80
Fork length (mm)	l	1150	1150	1150	1150
Fork width x thickness (mm)	nXS1	150x70	150x70	150x70	150x70
Overall length (mm)	L	1825	1825	1825	1825
Length of steering mechanism (mm)	L2	675	675	675	675
Overall width (mm)	B	850	850	850	850
Headroom (mm)	h1	2250	1780	1980	2250
Max. height (mm)	h4	3915	2985	3385	3915
Turning circle (mm)	Wa	1460	1460	1460	1460
Aisle width 800 x 1200 mm (mm)	Ast	2075	2075	2075	2075
Speed with/without load (km/h)		4.0/5.0	4.0/5.0	4.0/5.0	4.0/5.0
Lifting with/without load (m/s)		0.07/0.10	0.07/0.10	0.07/0.10	0.07/0.10
Lowering with/without load (m/s)		0.4/0.1	0.4/0.1	0.4/0.1	0.4/0.1
Max. gradient with/without load (%)		5/10	5/10	5/10	5/10
Own weight with battery (kg)		540	524	539	574
Steering/fork wheels (No)		2+1 M/2	2+1 M/2	2+1 M/2	2+1 M/2
Steering/fork wheels*		P+G/P	P+G/P	P+G/P	P+G/P
Dimensions of drive wheels (mmØ)		250x76	250x76	250x76	250x76
Dimensions of support wheels (mmØ)		150x40	150x40	150x40	150x40
Dimensions of fork wheels (mmØ)		82x70	82x70	82x70	82x70
Dist. betw. steering and fork wheels (mm)	Y	1190	1190	1190	1190
Dist. betw. fork wheels and fork ends (mm)	X	365	365	365	365
Traction motor (kW)		0.7	0.7	0.7	0.7
Lift motor (kW)		2.2	2.2	2.2	2.2
Traction (T)/starter battery (S)		S	T	T	T
Voltage (V)		24	24	24	24
Power (Ah)		92	130	130	130
Duration of charge (h)		3	5	5	5
Battery weight (kg)		44	78	78	78
Battery charger (V-A)		24-20	24-20	24-20	24-20

* P = polyurethane - G = rubber - N = nylon



- ✓ *180 Ah to 315 Ah battery*
- ✓ *External charger*
- ✓ *Lift height to 3800mm*
- ✓ *Extremely versatile*
- ✓ *Electrically actuated brake*
- ✓ *1-year warranty on parts!*
- ✓ *Option: platform*

Electric lift and propulsion!

REF 119TA8882
SERIES FX
 Electric lift and propulsion



Side opening for easy battery replacement

Solid cover provides protection and is easily removed for maintenance!



Solid central battery connector - easy to disconnect



Emergency stop, horn and buttons for precise speed regulation



Optional traction battery and charger!

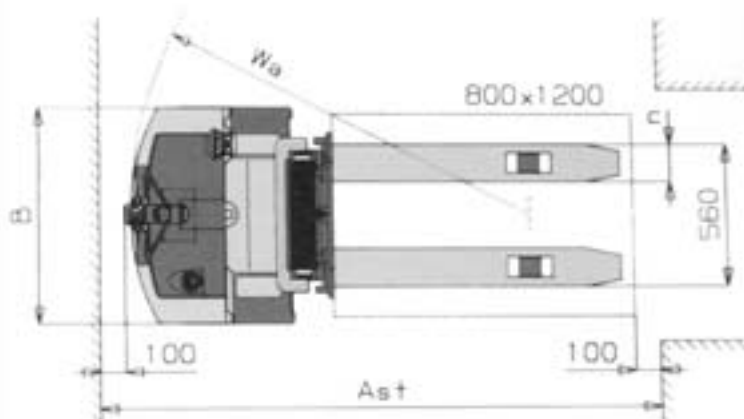
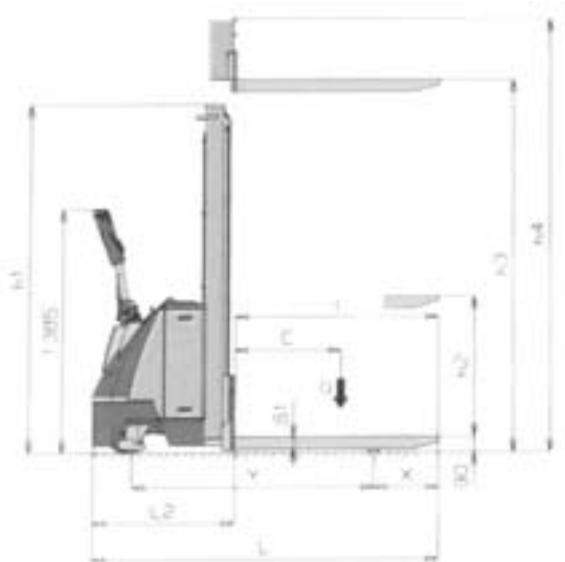

STACKERS ELECTRIC

REF		119TA8882	119TA8883	119TA8884
Features		FX 12/29	FX 12/35	FX 12/38
Lifting capacity (kg)	Q	1200	1200	1200
Load centre of gravity (mm)	C	600	600	600
Lift height (mm)	h3	2900	3500	3850
Free lift (mm)	h2	/	80	80
Fork length (mm)	l	1150	1150	1150
Fork width x thickness (mm)	nXS1	150x70	150x70	150x70
Overall length (platform in/out) (mm)	L	1957 (2042/2453)	1957 (2042/2453)	1957 (2042/2453)
Length of steering mechanism (platform in/out) (mm)	L2	807 (892/1303)	807 (892/1303)	807 (892/1303)
Width (mm)	B	850	850	850
Headroom (mm)	h1	1980	2250	2425
Maximum height (mm)	h4	3385	3915	4270
Turning circle (platform in/out) (mm)	Wa	1586 (1639/2096)	1586 (1639/2096)	1586 (1639/2096)
Aisle width 800 x 1200 (platform in/out) (mm)	Ast	2228 (2301/2712)	2228 (2301/2712)	2228 (2301/2712)
Speed with/without load		5.5/6	5.5/6	5.5/6
Lifting with/without load (m/s)		0.11/0.17	0.11/0.17	0.11/0.17
Lowering with/without load (m/s)		0.4/0.1	0.4/0.1	0.4/0.1
Maximum gradient with/without load (%)		5/10	5/10	5/10
Weight with battery (kg)		717	760	770
Steering/fork wheels (No)		2+1 M/2	2+1 M/2	2+1 M/2
Steering/fork wheels*		P+G/P	P+G/P	P+G/P
Dimensions drive wheel (mmØ)		250x76	250x76	250x76
Dimensions of support wheel (mmØ)		125x50	125x50	125x50
Dimensions of fork wheel (mmØ)		82x70	82x70	82x70
Dist. betw. steering and fork wheels	Y	1363	1363	1363
Dist. betw. fork wheels and fork ends	X	365	365	365
Traction motor (kW)		1.2	1.2	1.2
Lift motor (kW)		2.5	2.5	2.5
Electric speed limiter		Yes	Yes	Yes
Voltage/power (V/Ah)		24/180-315	24/180-315	24/180-315
Weight battery (min.-max.) (kg)		200-285	200-285	200-285

* P = polyurethane - G = rubber - N = nylon



- ✓ *Designed for years of intensive use!*
- ✓ *Fitted with traction battery of your choice (180-315Ah)*
- ✓ *Maximum lift height up to 4500 mm (triplex mast)*
- ✓ *Maximum capacity 1600 kg*

REF 108TA8966

SERIES LX
Electric lift and propulsion

- ✓ LX12: up to 1200 kg
- ✓ LX14: up to 1400 kg
- ✓ LX16: up to 1600 kg

Top product!



Better visibility through mast



Side opening for easy battery replacement

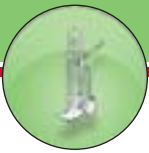

Optional traction battery and charger!

STACKERS ELECTRIC

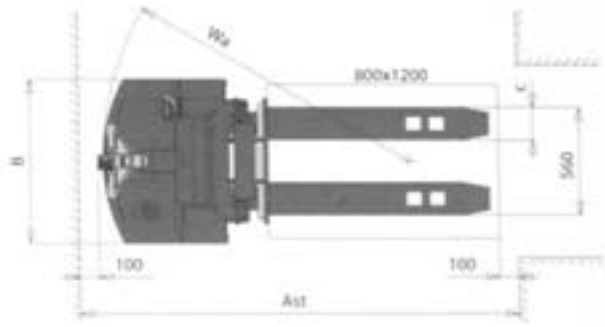
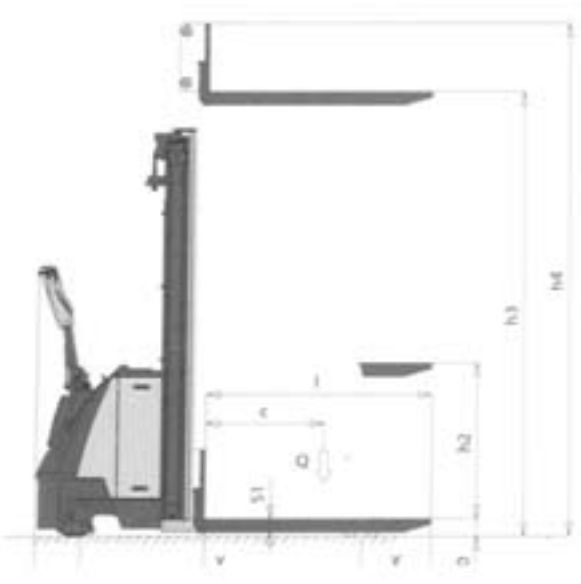

REF		108TA8958	108TA8959	108TA8960	108TA8961	108TA8966	108TA8962	108TA8963	108TA8964	108TA8965
Features		LX 12/16	LX 12/25	LX 12/29	LX 12/35	LX 14/45	LX 16/16	LX 16/25	LX 16/29	LX 16/35
Lifting capacity (kg)	Q	1200	1200	1200	1200	1400	1600	1600	1600	1600
Load centre of gravity (mm)	C	600	600	600	600	600	600	600	600	600
Lift height (mm)	h3	1600	2500	2900	3500	4500	1600	2500	2900	3500
Free lift (mm)	h2	1510	/	/	/	/	1510	/	/	/
Fork length (mm)	l	1150	1150	1150	1150	1150	1150	1150	1150	1150
Fork width x thickness (mm)	nXS1	150x70	150x70	150x70	150x70	170x70	170x70	170x70	170x70	170x70
Overall length	L	1964	1964	1964	1964	2001	1991	1991	1991	1991
(platform in/out) (mm)		(2056/2467)	(2056/2467)	(2056/2467)	(2056/2467)	(2093/2504)	(2083/2494)	(2083/2494)	(2083/2494)	(2083/2494)
Length of steering mechanism (platform in/out) (mm)	L2	809 (901/1312)	809 (901/1312)	809 (901/1312)	809 (901/1312)	851 (943/1354)	841 (933/1344)	841 (933/1344)	841 (933/1344)	841 (933/1344)
Width (mm)	B	850	850	850	850	850	850	850	850	850
Headroom (mm)	h1	1965	1765	1965	2265	2099	1965	1765	1965	2265
Maximum height (mm)	h4	1965	2970	3370	3970	5039	1965	2970	3370	3970
Turning circle (platform in/out) (mm)	Wa	1586 (1639/2096)	1586 (1639/2096)	1586 (1639/2096)	1586 (1639/2096)	1649 (1702/2159)	1649 (1702/2169)	1649 (1702/2169)	1649 (1702/2169)	1649 (1702/2169)
Aisle width 800 x 1200 (platform in/out) (mm)	Ast	2228 (2301/2712)	2228 (2301/2712)	2228 (2301/2712)	2228 (2301/2712)	2252 (2325/2736)	2241 (2314/2725)	2241 (2314/2725)	2241 (2314/2725)	2241 (2314/2725)
Speed with/without load		5.5/6	55.5/6	5.5/6	5.5/6	5.5/6	5.5/6	5.5/6	5.5/6	5.5/6
Lifting with/without load (m/s)		0.09/0.15	0.09/0.15	0.09/0.15	0.09/0.15	0.13/0.17	0.08/0.12	0.08/0.12	0.08/0.12	0.08/0.12
Lowering with/without load (m/s)		0.4/0.1	0.4/0.1	0.4/0.1	0.4/0.1	0.4/0.1	0.4/0.1	0.4/0.1	0.4/0.1	0.4/0.1
Max. gradient with/without load (%)		5/10	5/10	5/10	5/10	5/10	5/10	5/10	5/10	5/10
Weight with battery (kg)		650	725	780	790	1010	754	849	874	914
Steering, fork wheels (No)		2+1 M/2	2+1 M/2	2+1 M/2	2+1 M/2	2+1 M/4	2+1 M/4	2+1 M/4	2+1 M/4	2+1 M/4
Steering/fork wheels*		P+G/P	P+G/P	P+G/P	P+G/P	P+G/P	P+G/P	P+G/P	P+G/P	P+G/P
Dim. drive wheel (mmØ)		250x76	250x76	250x76	250x76	250x101	250x101	250x101	250x101	250x101
Support wheel (mmØ)		125x50	125x50	125x50	125x50	125x50	125x50	125x50	125x50	125x50
Fork wheels (mmØ)		82x70	82x70	82x70	82x70	82x70	82x70	82x70	82x70	82x70
Dist. betw. steering and fork wheels (mm)	Y	1363	1363	1363	1363	1429	1429	1429	1429	1429
Dist. betw. fork wheels and fork ends (mm)	X	371	371	371	371	353	332	332	332	332
Traction motor (kW)		1.2	1.2	1.2	1.2	1.2	1.2	1.2	1.2	1.2
Lift motor (kW)		2.5	2.5	2.5	2.5	3	2.5	2.5	2.5	2.5
Electric speed control		Yes	Yes	Yes	Yes	Yes	Yes	Yes	Yes	Yes
Voltage/power (V/Ah)		24/180-315	24/180-315	24/180-315	24/180-315	24/180-315	24/180-315	24/180-315	24/180-315	24/180-315
Weight battery (min.-max.) (kg)		200-285	200-285	200-285	200-285	200-285	200-285	200-285	200-285	200-285

* P = polyurethane - G = rubber - N = nylon



Free lift up to 1510mm

- ✓ *For areas with a low ceiling*
- ✓ *Electrically actuated brake*
- ✓ *Fitted with traction battery of your choice*
- ✓ *3 KW motor*

For intensive use!

REF 119TA8867
SERIES LX Freelift
 Electric lift and propulsion

Tandem polyurethane fork wheels



Free lift up to 1510 mm



Charge via external charger



Side opening for easy battery replacement



Emergency stop, horn and side buttons for precise speed regulation



Optional traction battery and charger!

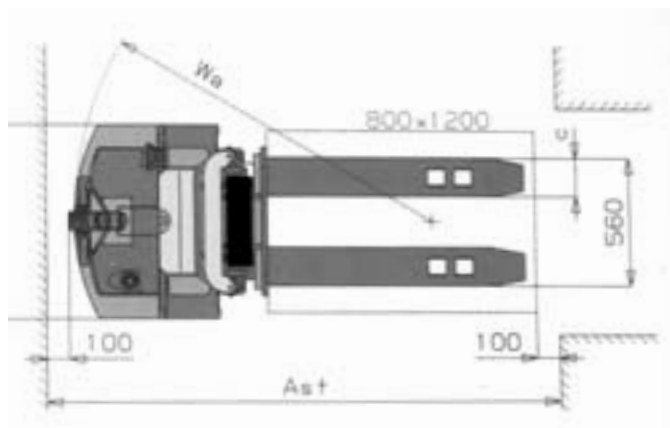
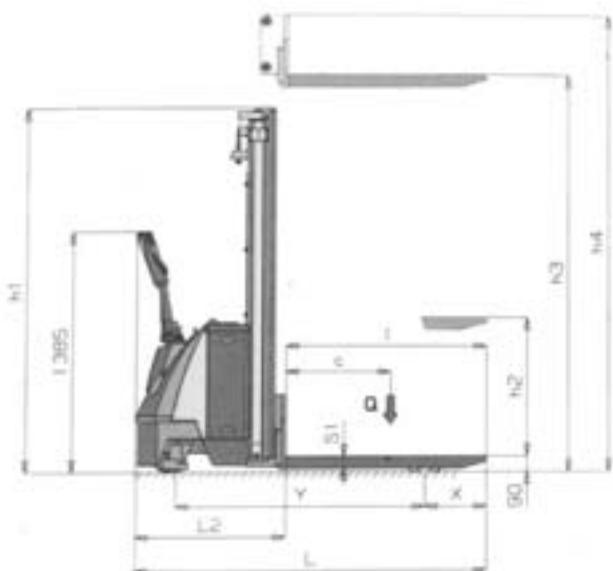

STACKERS ELECTRIC

REF	119TA8867	
Features	LX 14/45 Free Lift	
Lifting capacity (kg)	Q	1400
Load centre (mm)	C	600
Lift height (mm)	h3	4500
Free lift (mm)	h2	1510
Fork length (mm)	l	1150
Fork width x thickness (mm)	nXS1	170x70
Overall length (platform in/out) (mm)	L	2001 (2093/2504)
Length of steering mechanism (platform in/out) (mm)	L2	851 (943/1354)
Width (mm)	B	850
Headroom (mm)	h1	2122
Maximum height (mm)	h4	5062
Aisle width 800 x 1200 (platform in/out) (mm)	Ast	1649 (1702/2159) 2252 (2325/2736)
Speed with/without load		5.5/6
Lifting with/without load (m/s)		0.12/0.17
Lowering with/without load (m/s)		0.4/0.1
Maximum gradient with/without load (%)		5/10
Weight with battery (kg)		1069
Steering/fork wheels (No)		2+1 M/4
Steering/fork wheels*		P+G/P
Dimensions of drive wheel (mmØ)		250x101
Dimensions of support wheel (mmØ)		125x50
Dimensions of fork wheel (mmØ)		82x70
Dist. betw. steering and fork wheels (mm)	Y	1429
Dist. betw. fork wheels and fork ends (mm)	X	353
Traction motor (kW)		1.2
Lift motor (kW)		3
Electric speed limiter		Yes
Voltage/power (V/Ah)		24/180-315
Weight of battery (min.-max.) (kg)		200-285

* P = polyurethane - G = rubber - N = nylon



Adjustable forks and stabilisers!

- ✓ *Ideal for lifting pallets of different sizes*
- ✓ *With built-in battery and charger*
- ✓ *1-year guarantee on parts!*
- ✓ *Optional: maintenance-free gel battery*

REF 108TA8955

SERIES TX
Electric lift, manual propulsion



REF 108TA8956

SERIES GX
Electric lift and propulsion



Ergonomic handle with battery indicator, emergency brake and horn

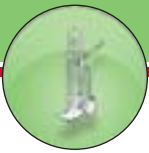

Battery and charger included!

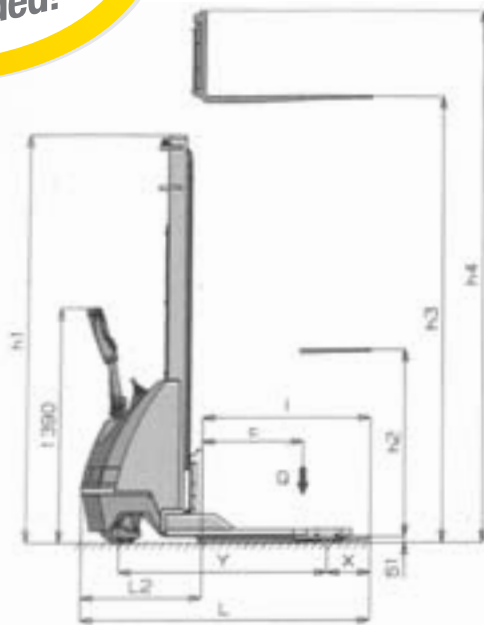
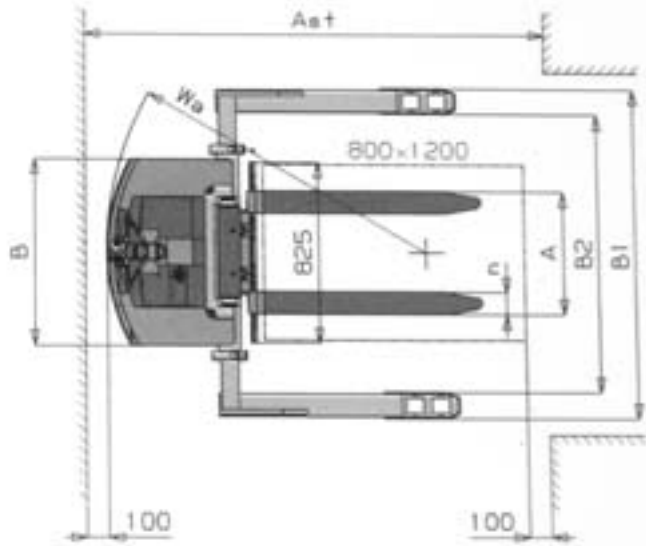

REF		108TA8955	108TA8956	108TA8957	111TA4226	111TA4227
Features		TX 10/16 STRADDLE	GX 12/25 STRADDLE	GX 12/35 STRADDLE	GX 12/25 PLUS STRADDLE	GX 12/35 PLUS STRADDLE
Lifting capacity (kg)	Q	1000	1200	1200	1200	1200
Load centre (mm)	C	600	600	600	600	600
Lift height (mm)	h3	1550	2450	3450	2450	3450
Free lift (mm)	h2	1415	/	80	/	80
Fork length (mm)	l	1000	1000	1000	1000	1000
Fork width x thickness (mm)	nXS1	100x35	100x35	100x35	100x35	100x35
Overall length (mm)	L	1640	1715	1715	1715	1715
Length of steering mechanism (mm)	L2	640	715	715	715	715
Overall width (mm)	B	750	850	850	850	850
Headroom (mm)	h1	1970	1780	2250	1780	2250
Adjust. forks (min/max) (mm)	A	230-790	230-790	230-790	230-790	230-790
Min. width (min/max) (mm)	B1	1197-1504	1197-1504	1197-1504	1197-1504	1197-1504
Space for pallet (min/max) (mm)	B2	963-1270	963-1270	963-1270	963-1270	963-1270
Max. height (mm)	h4	2070	2985	3915	2985	3915
Turning circle (mm)	Wa	1790	1460	1460	1460	1460
Aisle width 800 x 1200 (mm)	Ast	2400	2116	2116	2116	2116
Speed with/without load (km/h)		/	4.0/5.0	4.0/5.0	4.0/5.0	4.0/5.0
Lifting with/without load (m/s)		0.09/0.12	0.07/0.10	0.07/0.10	0.07/0.10	0.07/0.10
Lowering with/without load (m/s)		0.4/0.1	0.4/0.1	0.4/0.1	0.4/0.1	0.4/0.1
Max. gradient with/without load (%)		/	5/10	5/10	5/10	5/10
Own weight with battery (kg)		415	570	620	604	654
Steering/fork wheels (No)			2+1 M/2	2+1 M/2	2+1 M/2	2+1 M/2
Steering/fork wheels*		G/N	P+G/P	P+G/P	P+G/P	P+G/P
Dim. drive wheels (mmØ)		/	250x76	250x76	250x76	250x76
Dim. support wheels (mmØ)		200x50	150x40	150x40	150x40	150x40
Dim. fork wheels (mmØ)		82x70	82x70	82x70	82x70	82x70
Dist. betw. steering and fork wheels (mm)	Y	1130	1190	1190	1190	1190
Dist. betw. fork wheels and fork ends (mm)	X	246	255	255	255	255
Mechanical (M)/electr. (E) brake		M	E	E	E	E
Traction motor (kW)		/	0.7	0.7	0.7	0.7
Lift motor (kW)		1.6	2.2	2.2	2.2	2.2
Electric speed control		/	Yes	Yes	Yes	Yes
Traction (T)/starter battery (S)		S	S	S	T	T
Voltage/power (V/Ah)		12/70	2x12/92	2x12/92	2x12/130	2x12/130
Duration of charge (h)		/	3	3	5	5
Weight of battery (min-max) (kg)		18	44	44	78	78
Battery charger (V-A)		12/15	24-20	24-20	24-20	24-20

* P = polyurethane - G = rubber - N = nylon

- ✓ For lifting loads of 100 to 250 kg
- ✓ With battery and integrated charger
- ✓ European quality make!
- ✓ Prevent back problems!

HALLINS

Very
lightweight
stackers!



REF 111TA4233 - 111TA4236

Hallins Ergonomic stacker
Newton 150 - 250 series

REF 111TA4231 - 111TA4232

Hallins Ergonomic stacker
Newton 100 series

REF	111TA4231	111TA4232	111TA4233	111TA4234	111TA4235
Features	Newton 100	Newton 100	Newton 150	Newton 150	Newton 250
Lift height (mm)	1500	1700	1500	1700	1520
Height (mm)	1870	2070	1870	2070	1900
Length (mm)	875	875	875	875	900
Width (mm)	525	625	525	625	600
Min. lift height (mm)	145	145	145	145	150
Lifting speed (mm/s)	100	100	80	80	80
Lifting capacity (kg)	100	100	150	150	250
Weight (kg)	40	40	44	44	60
Protection rating	IP41	IP41	IP41	IP41	IP41
Dimensions of platform (mm)	525 x 470	525 x 470	525 x 470	525 x 470	550 x 500

Designed for use in the chemical and food industries where water, moisture and salt are present. These stainless steel products are low-maintenance and comply with safety and hygiene standards!



Stainless steel!

- ✓ *Ideal for the chemical and food industry!*
- ✓ *Extremely versatile units!*



REF 111TA4238

**Ergonomic stacker
Reflex 70 Stainless steel**



REF 111TA4237

Reflex 70 ergonomic stacker



Option: stainless steel platform

REF 111TA4239

Reflex 200 ergonomic stacker

REF	111TA4237	111TA4238	111TA4239
Features	Reflex 70 White	Reflex 70 Stainless	Reflex 200 Stainless
Lift height (mm)	1465	1465	1500
Min. lift height (mm)	140	140	100
Dimensions of platform (mm)	595 x 470	595 x 470	n/a
Lifting speed (mm/s)	100	100	100
Lifting capacity (kg)	70	70	200
Weight (kg)	43	43	100

✓ *Accessories for ergonomic stackers available*

Stainless steel



Linda

For lifting rolls

- ✓ Length: 500 mm
- ✓ Max. Ø rolls: 250 mm
- ✓ Rotation: 360°
- ✓ Stainless steel



Liz

Manual rotator for rolls

- ✓ Lifting capacity: 80 kg
- ✓ Ø: 70 or 76 mm
- ✓ Length roll: 300 - 500 mm
- ✓ Rotation: 360°
- ✓ Stainless steel



Jeeves

Lifting platform stainless steel

- ✓ Fits over standard polyethylene platform
- ✓ Length: 460 mm
- ✓ Width at base: 520 mm
- ✓ Stainless steel



Alex

Roll spindle

- ✓ Length: 530 mm
- ✓ Ø: 50 mm
- ✓ Stainless steel



Barbara

Forks for rolls and cylinders

- ✓ Length of forks: 500mm*
- ✓ Length of forks: 545 mm
- ✓ Overall width: 288 mm
- ✓ Distance between forks: 192 mm*
- ✓ Stainless steel

* other sizes possible



Benny

Clamp rotator (electric drive)

- ✓ For forks, rolls and cylinders. Fits Newton 150 or Reflex 200.
- ✓ Lifting capacity: 100 kg
- ✓ Max. Ø rolls: 490 mm
- ✓ Min. Ø rolls: 350 mm
- ✓ Rotation: 360°
- ✓ Stainless steel
- ✓ Inside of clamp has rubber lining

- ✓ *Extremely versatile and easy to drive!*
- ✓ *Electric lift up to 1500 mm!*
- ✓ *European quality make!*
- ✓ *Built-in 24 V/6 A charger!*

New models!



REF 107TA8251

Ergonomic stacker

Option: curved platform

For holding round loads

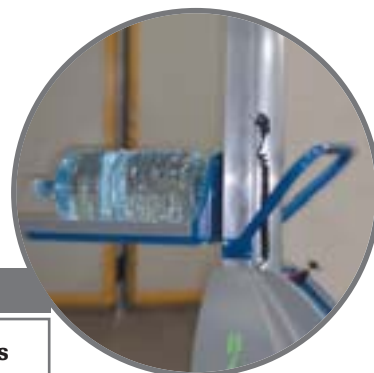

Option: short forks

For holding small pallets

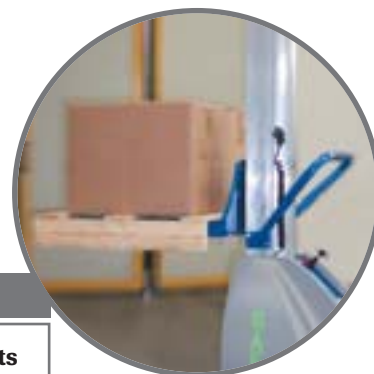

Option: spindle

For holding rolls



REF	107TA8251	121TA1105	121TA1106
Lift height (mm)	80/1500	80/2000	80/1500
Lifting capacity (kg)	100	100	200
Lifting speed (mm/s)	8.3 - 6.0	8.3 - 6.0	8.3 - 4.2
Front wheels (mm)	80 x 30	80 x 30	80 x 30
Rear wheels (mm)	100 x 30	100 x 30	100 x 30
Battery	2 x 12 V/17 Ah	2 x 12 V/40 Ah	2 x 12 V/40 Ah
Weight (kg)	86	115	106
Overall length and width (mm)	866 x 500	866 x 500	866 x 500