

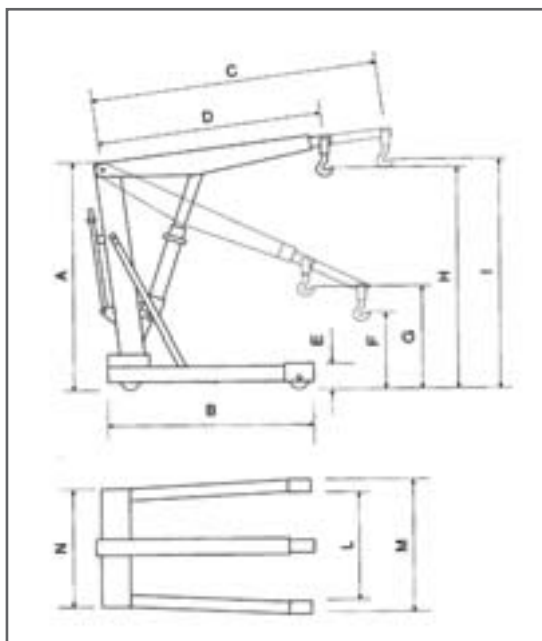

✓ *Cranes with a safety valve!*

REF 108TA8274 TO 108TA8360

Lifts loads of up to 2000 kg

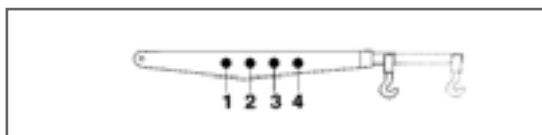

REF 108TA8361 TO 108TA8364

Lifts loads of up to 2000 kg

REF	a	b	c	d	e	f	g	h	i	l	m	n	kg	1 (kg)	2 (kg)	3 (kg)	4 (kg)
107TA8274	1620	1280	1300	1000	160	520	730	2200	2400	780	900	640	65	500	400	250	150
108TA8495	1750	1500	1550	1250	165	620	800	2520	2750	920	1020	750	100	1000	800	500	300
108TA8359	1840	1690	1850	1400	195	430	720	2820	3220	880	1020	1000	180	1500	1200	800	500
108TA8360	1990	1640	1970	1520	220	520	800	2930	3270	980	1120	1100	220	2000	1500	1000	600
108TA8361	1610	1280	1440	1040	150	460	680	2180	2380	775	885	600	80	500	400	250	150
108TA8362	1740	1500	1545	1245	165	525	720	2440	2650	900	1010	700	130	1000	800	500	300
108TA8363	1850	1790	1840	1390	195	470	750	2860	3280	1000	1150	1140	220	1500	1200	800	600
108TA8364	2000	1970	1950	1500	220	530	810	2930	3280	1150	1350	1340	300	2000	1500	1000	600

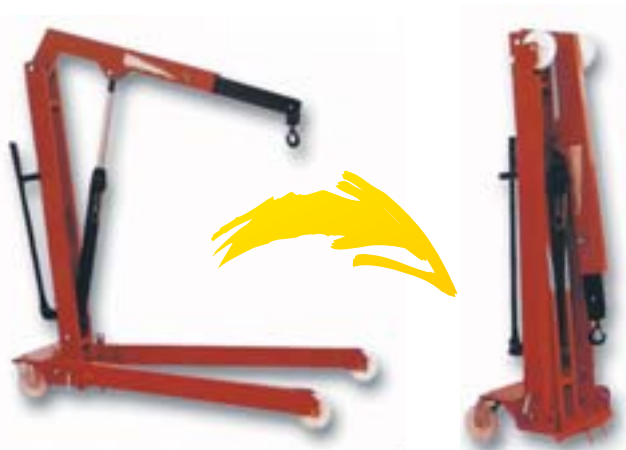

- ✓ *Folding cranes: very compact*
- ✓ *Safety valve to prevent overload*

REF 107TA8275 AND 108TA8365

Lifts loads of up to 1000 kg

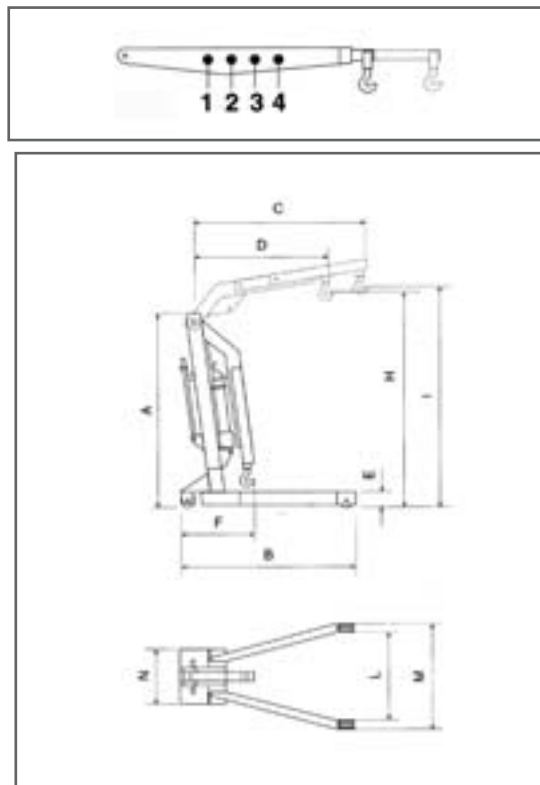

REF	A	B	C	D	E	H	I	L	M	N	kg	1 (kg)	2 (kg)	3 (kg)	4 (kg)
107TA8275	1630	1540	1230	940	140	1940	2070	720	830	430	80	500	400	250	150
108TA8365	1650	1560	1380	1080	165	2220	2400	870	980	550	110	1000	800	500	300



REF 108TA8366 - 108TA8367

Lifts loads of up to 1000 kg

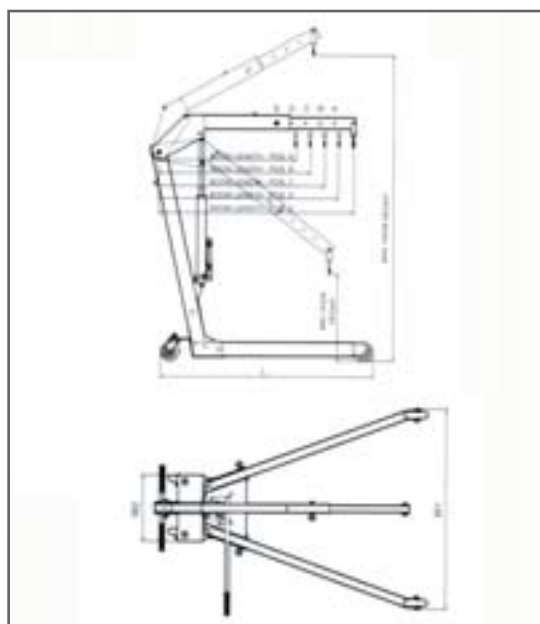

REF No.	Position	Capacity (kg)	Min. height (mm)	Max. height (mm)	Lever	Dimensions			Net Weight (kg)
						L (mm)	W1 (mm)	W2 (mm)	
108TA8366 (1/2 tonne) Folding	A	500	485	1750	510	1207	940	325	61,9
	B	450	395	1785	600	1207	940	325	61,9
	C	400	305	1820	690	1207	940	325	61,9
	D	350	215	1855	780	1207	940	325	61,9
108TA8367 (1 tonne) Folding	E	300	125	1890	870	1470	1120	370	77
	A	1000	517	1930	620	1470	1120	370	77
	B	900	420	1985	720	1470	1120	370	77
	C	800	323	2035	820	1470	1120	370	77
D	700	230	2090	920	1470	1120	370	77	

HYDRAULIC CRANES (FOLDING)



2-tonne capacity!

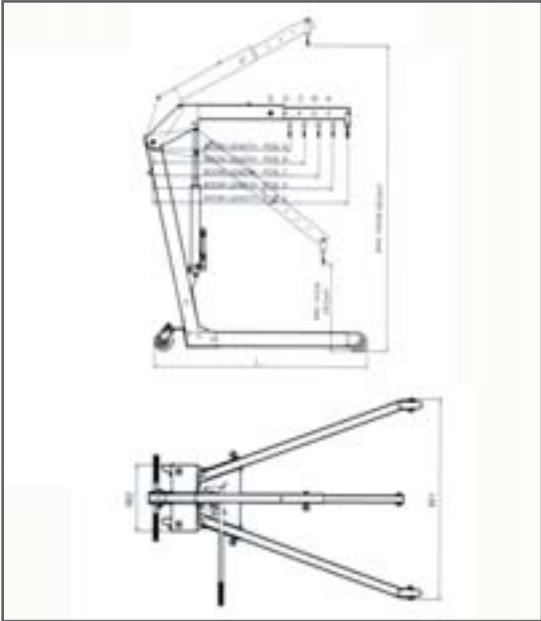

REF 108TA8368
Non-folding!

REF No.	Position	Capacity (kg)	Min. height (mm)	Max. height (mm)	Lever	Dimensions			Net Weight (kg)
						L (mm)	W1 (mm)	W2 (mm)	
108TA8368 (2 tonnes) Non-folding	E	600	127	2145	1020	1585*	735*	880*	105
	A	2000	435	1760	1195	1585	735	880	105
	B	1500	320	1910	1420	1585	735	880	105
	C	1000	205	2065	1645	1585	735	880	105
	D	500	95	2215	1870	1585	735	880	105

* Extended: L= 2305 mm / W1= 860 mm / W2= 1350 mm



GRAY US PRODUCT



REF 124TA7010
Air - hydraulic jack 4000 kg

No more pumping (quick rise)
Two position handle (portable)
Precise operator control
Slower descent rate

Standard shop air!



REF 124TA7142
Hydraulic jack 4000 kg

Turbomotor®
Compact & powerfull
Dual lift positions
Quick connect air motor adaptable



REF 116TA6976
Hydraulic jack 4000 kg

Light weight

REF	Lifting capacity (kg)	Min. height (mm)	Max. height (mm)	Weight (kg)
124TA7010	4000	57	406	33
124TA7142	4000	55	765	41,3
116TA6976	4000	60	420	21

✓ 1-year guarantee on parts!



REF 105TA4621

Hydraulic jack 4000-5000 kg



REF 107TA8190

Hydraulic jack 7000 kg



REF 107TA8185

Hydraulic jack 4000 kg

ABSOLUTE TOP QUALITY!



double lift

REF 107TA8192 - 107TA8193 - 107TA8194

Hydraulic jack 5000 to 25,000 kg



REF 107TA8188 - 107TA8189

Hydraulic jack 6000 kg or 10,000 kg

REF	Lifting capacity (kg)	Min. height (mm)	Max. height (mm)	Weight (kg)
105TA4621	4000/5000	55	430	38.5
107TA8190	7000	57	406	42
107TA8185	4000	60	360	31
107TA8192	5000	25/368	231/574	20
107TA8193	10000	25/413	258/646	27.5
107TA8194	25000	58/470	291/703	92
107TA8188	6000	60	400	38
107TA8189	10000	60	400	40

- 106TA8633 > Repair kit for 107TA5331 and 107TA8185
- 106TA8634 > Repair kit for 105TA4621
- 106TA8635 > Repair kit for 107TA8187
- 106TA8636 > Repair kit for 107TA8188

✓ *Bottle jacks with lifting capacity of 2 to 100 tonnes!*



REF 107TA8203

Hydr. jack 2000 kg



REF 107TA8205

Hydr. jack 4000 kg



REF 107TA8207

Hydr. jack 6000 kg



REF 107TA8208

Hydr. jack 8000 kg



REF 107TA8210

Hydr. jack 12,000 kg



REF 107TA8211

Hydr. jack 15,000 kg



REF 107TA8214

Hydr. jack 30,000 kg



REF 107TA8216

Hydr. jack 100,000 kg

REF	Lifting capacity (tonnes)	Min. height (A)(mm)	Hydr.L. (B) (mm)	(C) (mm)	Max. H. (D) (mm)	Weight (kg)
107TA8203	2	181	115	50	346	2.7
107TA8204	2	157	180	50	387	3.7
107TA8205	4	204	126	60	390	3.8
107TA8206	4	181	201	60	442	5.7
107TA8207	6	217	130	75	422	4.8
107TA8208	8	225	152	70	447	5.7
107TA8209	12	240	153	80	473	8.0
107TA8210	12	152	79	40	271	6.5
107TA8211	15	265	170	80	515	10.1
107TA8212	20	240	153	80	473	12.2
107TA8213	20	165	80	40	285	9.9
107TA8214	30	280	180	n/a	460	24.3
107TA8215	50	305	178	n/a	483	50.4
107TA8216	100	305	155	n/a	460	90.6

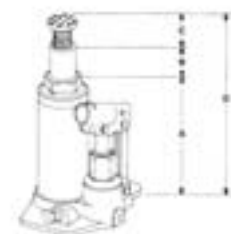

Capacity up to 100 tonnes!

- ✓ *Built-in overpressure valve*
- ✓ *Rapid lifting using foot pedal*

REF 107TA8220

Hydr. jack 1500 kg

REF 107TA8217

Hydr. jack 2000 kg

Easy to move

REF 107TA8221

Hydr. jack 3000 kg

REF 107TA8218

Hydr. jack 2000 kg

REF 107TA8222

Hydr. jack 1500 kg

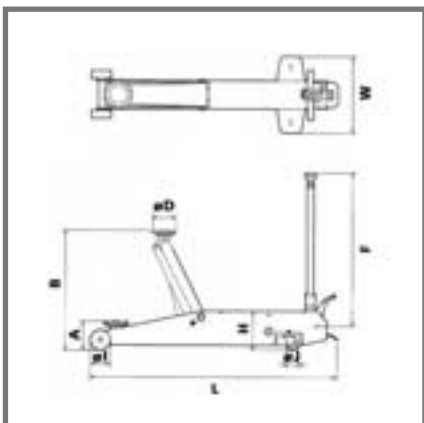

REF 107TA8219

Hydr. jack 5000 kg

REF	Lifting capacity (tonnes)	A (mm)	B (mm)	Ø D (mm)	F (mm)	Ø I (mm)	Ø J (mm)	L (mm)	W (mm)	H (mm)	Weight (kg)
107TA8220	1,5	140	812	152	1,010	80	100	1,090	453	180	58,6
107TA8221	3	133	483	140	1,010	92	58	637	341	170	37,3
107TA8222	1,5	132	805	165	1,010	92	73	960	417	283	52,8
107TA8217	2	127	534	120	1,019	98	73	1,003	412	168	34
107TA8218	2	127	914	140	1,069	110	58	1,659	374	200	76,8
107TA8219	5	178	686	167	1,068	110	58	1,468	430	195	98



Large base!

Safety handle with folding grip

REF 116TA5786

Mechanical jack 1500 kg

Lifts heavy loads easily!

REF	Lifting capacity (tonnes)	Chassis height (mm)	Lifting height (mm)	Foot height in lowest pos. (mm)	Weight (kg)
116TA5786	1,5	725	350	70	14
116TA5787	3	725	350	75	20,5
116TA5788	5	725	300	70	26,5
116TA5789	10	800	300	90	43
116TA5790	20	800	340	95	63
116TA5791	1,5	570	300	70	12,5
116TA5792	3	570	300	75	19
116TA5793	5	600	300	70	23,2
116TA5794	10	650	300	80	39



ADJUSTABLE LIFTING FOOT!

Large base!

Safety handle with folding grip

REF 116TA5795

Mechanical jack 3000 kg

Lifts heavy loads easily!

Lifting capacity (tonnes)	Pos. 6 (mm)	Pos. 5 (mm)	Pos. 4 (mm)	Pos. 3 (mm)	Pos. 2 (mm)	Pos. 1 (mm)
3	554	457	360	263	166	69
5	549	452	355	258	161	64
10	615	509	403	297	191	85
15	580	483	386	289	192	95

REF	Lifting capacity (tonnes)	Chassis height (mm)	Lifting height (mm)	Foot height in lowest pos. (mm)	Weight (kg)
116TA5795	3	720	350	69	25
116TA5796	5	720	300	70	30
116TA5797	10	792	300	85	48
116TA5799	15	805	285	105	70



REF 116TA6975

Screw jack

- ✓ Versatile
- ✓ Maintenance-free
- ✓ Lifting capacity: 3000 kg
- ✓ Minimum height: 153 mm
- ✓ Maximum height: 1070 mm

Ideal for vertical lifting, horizontal pulling, jacking up liftrucks and jeeps!



✓ *Sold in pairs!*

REF 105TA4047

Extra wide base!!!

Wide-base props

- ✓ Capacity: 9000 kg
- ✓ Minimum height: 240 mm
- ✓ Maximum height: 420 mm



✓ *Sold individually!*

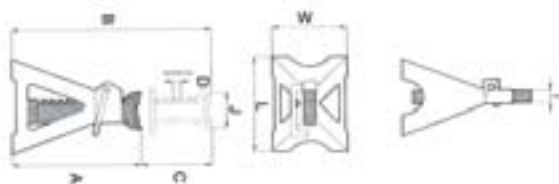

REF	Lifting capacity (tonnes)	Min. height (mm)	Max. height (mm)	C (mm)	D (mm)	I (mm)	J (mm)	L (mm)	W (mm)	Weight (kg)
107TA8195	3	292	432	140	16	27	94	195	170	6,8
107TA8196	6	390	618	228	18	32	110	270	230	13,3
107TA8197	12	445	700	255	24	39	118	307	274	26,6



✓ *Sold individually!*

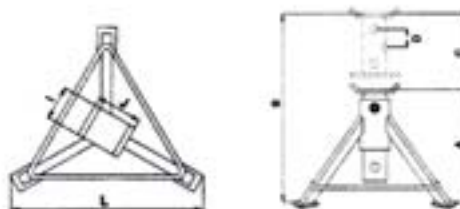

REF	Lifting capacity (tonnes)	Min. height (mm)	Max. height (mm)	C (mm)	D (mm)	I (mm)	J (mm)	L (mm)	Weight (kg)
107TA8198	3	290	433	143	28,6	60	80	210	4,8
107TA8199	6	365	565	200	40	75	105	285	11
107TA8200	12	485	750	265	53	95	130	315	23,5
107TA8201	15	500	820	320	64	95	130	400	32
107TA8202	20	550	900	350	70	95	130	450	36

✓ *Ramp for liftrucks!*

SOLD IN PAIRS!

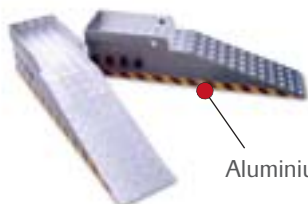

Aluminium: light but strong!

REF 111TA9284

Ramp for liftrucks



REF	Length (mm)	Height-max (mm)	Width-max (mm)	Weight/unit (kg)	Load capacity (kg)
111TA9284	1200	280	260	16	4000

- ✓ *Extremely solid aluminium wheel chock*
- ✓ *Easier to see*
- ✓ *Easy to move, without bending: no back problems*

Light but extremely strong!



Easy to position

Easy to remove

Visible

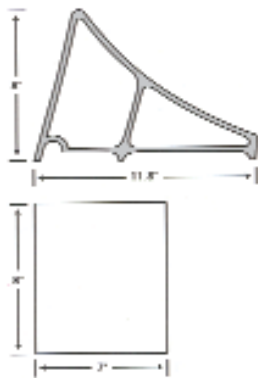

REF 116TA6235

Aluminium wheel chocks with handle

Height: 203.2 mm
 Width: 187.9 mm
 Length: 299.7 mm
 Weight: 3.15 kg

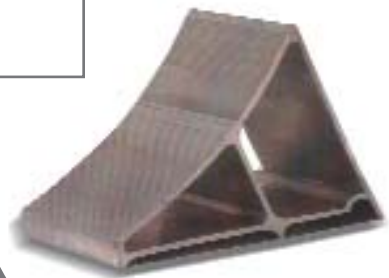

REF 105TA4044
1.5 tonnes

REF 105TA4045
5 tonnes

REF 105TA4048
6.5 tonnes

REF 106TA6391 - Rubber -
for lorry - 20 tonnes

